

# Bearingless encoders

<b>Incremental, large hollow shaft magnetic</b>	<b>RLI200 (hollow shaft)</b>	<b>Push-pull / RS422</b>
---	------------------------------	--------------------------



Thanks to its installation depth of min. 10 mm, the bearingless magnetic rotary encoder RLI200, comprising a magnetic ring and sensor head, is ideally suited for plants and machinery where space is very tight. The non-contact measuring principle allows for error-free use even under harsh environmental conditions, as well as ensuring a long service life.

**IP68 / IP69k protection, special encapsulation technology and tested resistance to cyclic humidity and damp heat offer the highest levels of reliability, even in exposed outdoor use.**

**This bearingless encoder can be mounted on shafts with a diameter up to max. 390 mm.**



High rotational speed	High protection level	Shock / vibration resistant	Reverse polarity protection

### Hard-wearing and robust

- High shock and vibration resistance.
- Sturdy housing with IP67 protection. Option: special housing for maximum resistance against condensation (IP68 / IP69k, resistance to cyclic humidity acc. to EN 60068-3-38 as well as damp heat acc. to EN 60068-3-78).
- Non-contact measuring system, free from wear, ensures a long service life.

### Fast start-up

- Requires very little installation space.
- Large mounting tolerance between magnetic band and sensor head.
- Slotted hole fixing ensures simple alignment.
- Function display via LED.

<b>Order code</b> RLI200	<b>8.RLI200</b>	<b>. XX 1 XX</b>	<b>. XXXXX</b>	<b>. XXXX</b>
	Type	a b c d	e	f

**a** *Magnetic ring mounting method*

- 1 = Press fit
- 2 = Hub screw <sup>1)</sup>
- 3 = Screwed flange <sup>1)</sup>

**b** *Model*

- 1 = IP67, standard
- 2 = IP68 / IP69k and humidity tested acc. to EN 60068-3-38, EN 60068-3-78

**c** *Output circuit / Supply voltage*

- 1 = RS422 / 4.8 ... 26 V DC
- 2 = Push-pull / 4.8 ... 30 V DC

**d** *Type of connection*

- 1 = radial cable, 2 m [6.56'] PUR
- A = radial cable, special length PUR \*)
- \*) Available special lengths <sup>2)</sup> (connection type A): 3, 5, 8, 10, 15, 20 m [9.84, 16.40, 26.25, 32.80, 49.21, 65.62']  
order code expansion .XXXX = length in dm  
ex.: 8.RLI200.1111A.07000.0760.0030 (for cable length 3 m)

**e** *Pulses per revolution*

- 700, 2240, 2800, 7000 (for hollow shaft ø 76 mm)
- 1600, 5120, 6400, 16000 (for hollow shaft ø 180 mm)
- (e.g.: 1600 pulses => 016000)

**f** *Hollow shaft diameter*

- 0760 = 76 mm [2.99"] <sup>3)</sup>
- 1800 = 180 mm [7.09"] <sup>3)</sup>

*Optional on request*  
- other pulse rates  
- other hollow shaft diameter (up to max. 390 mm)

#### Press fit



#### Hub screw





#### Screwed flange



1) On request.  
2) Cable lengths >10 m only possible with supply voltage >10 V.  
3) With magnetic ring mounting method 2 or 3 on request.

# Bearingless encoders

<b>Incremental, large hollow shaft magnetic</b>	<b>RLI200 (hollow shaft)</b>	<b>Push-pull / RS422</b>
---	------------------------------	--------------------------

Accessories / Displays		Order no.
<b>Codix 560, preset counter</b> <b>6-digit</b> 	<ul style="list-style-type: none"> <li>- Counter, tachometer, time counter and position display in one device</li> <li>- Scalable display</li> <li>- Readable via RS232/485 interface or configurable via MODBUS or CR/LF protocol</li> </ul>	<b>6.560.010.XXX</b>
<b>571T touch, multifunction preset counters</b> <b>8-digit</b> 	<ul style="list-style-type: none"> <li>- Measuring function for RPM, speed, speed from elapsed time, machine cycle time, throughput time (reciprocal rotary speed), as well as numerous count functions such as position display</li> <li>- Fast counting input (250 kHz/HTL, 1 MHz/RS422)</li> <li>- 4 switching outputs as limit values (response time &lt; 1 ms)</li> <li>- Scalable analog output (response time &lt; 150 ms), resolution 16 bit</li> <li>- Serial interface RS232 or RS485 for reading in and out the data</li> </ul>	<b>6.571T.01X.XXX</b>

Further Kübler accessories can be found at: [kuebler.com/accessories](http://kuebler.com/accessories)  
 Further Kübler cables and connectors can be found at: [kuebler.com/connection-technology](http://kuebler.com/connection-technology)

## Technical data

Mechanical characteristics		
<b>Maximum speed</b>		12000 min <sup>-1</sup>
<b>Protection</b>	Model 1	IP67 acc. to EN 60529
	Model 2	IP68 / IP69k acc. to EN 60529, DIN 40050-9 and humidity tested acc. to EN 60068-3-38, EN 60068-3-78
<b>Working temperature</b>		-20 °C ... +80 °C [-4 °F ... +176 °F]
<b>Shock resistance</b>		5000 m/s <sup>2</sup> , 1 ms
<b>Vibration resistance</b>		300 m/s <sup>2</sup> , 10 ... 2000 Hz
<b>Pole gap</b>		2 mm from pole to pole
<b>Housing (sensor head)</b>		aluminum
<b>Cable</b>		2 m [6.56'] long, PUR 8 x 0.14 mm <sup>2</sup> [AWG 26], shielded, may be used in trailing cable installations
<b>Status LED</b>	green	pulse-index
	red	error; speed too high or magnetic fields too weak

Electrical characteristics				
Output circuit	RS422		Push-pull	
<b>Supply voltage</b>	4.8 ... 26 VDC		4.8 ... 30 VDC	
<b>Power consumption (no load)</b>	typ. 25 mA max. 60 mA		typ. 25 mA max. 60 mA	
<b>Permissible load / channel</b>	120 Ohm		+/- 20 mA	
<b>Min. pulse edge interval</b>	1 µs		1 µs	
<b>Signal level</b>	HIGH	min. 2.5 V max. 0.5 V	min. +V - 2.0 V max. 0.5 V	
	LOW			
<b>Reference signal</b>	index periodical <sup>1)</sup>			
<b>System accuracy</b>	typ. 0.3° with shaft tolerance g6			
<b>Pulse rate [ppr] <sup>2)</sup></b>	<b>700</b>	<b>2240</b>	<b>2800</b>	<b>7000</b>
	max. speed min <sup>-1</sup>	12000	6600	5300
	<b>1600</b>	<b>5120</b>	<b>6400</b>	<b>16000</b>
	max. speed min <sup>-1</sup>	9300	2900	2300

Approvals		
<b>CE compliant</b> in accordance with		
	EMC Directive	2014/30/EU
	RoHS Directive	2011/65/EU

### Signal figures

- 1) Pulse edge interval: Pay attention to the instructions in the technical data
- 2) Periodic index signal every 2 mm [0.08"]; the logical assignment A, B and 0-signal can change

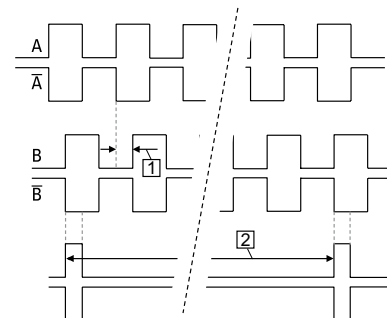

1) At every pole change. The signal is generated by the sensor.  
 2) With an input frequency of the evaluation unit of 250 kHz.

# Bearingless encoders

<b>Incremental, large hollow shaft magnetic</b>	<b>RLI200 (hollow shaft)</b>	<b>Push-pull / RS422</b>
---	------------------------------	--------------------------

## Terminal assignment

Output circuit	Type of connection	Cable (isolate unused cores individually before initial start-up)									
		1, 2	1, A	Signal:	0 V	+V	A	$\bar{A}$	B	$\bar{B}$	0
		Core color:	WH	BN	GN	YE	GY	PK	BU	RD	shield <sup>1)</sup>

- +V: Supply voltage encoder +V DC
- 0 V: Supply voltage encoder ground GND (0 V)
- A,  $\bar{A}$ : Incremental output channel A / cosine signal
- B,  $\bar{B}$ : Incremental output channel B / sine signal
- 0,  $\bar{0}$ : Reference signal
- $\perp$ : Plug connector housing (shield)

## Mounting orientation and permissible mounting tolerances

### Distances

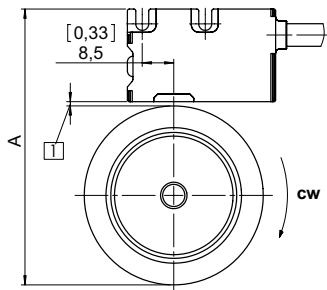

- 1 Distance sensor head / magnetic ring:  
0.1 ... 1.0 (0.4 [0.02] recommended)

Pulse rate	A for distance sensor head / magnetic ring = 0.4 mm [0.02]
700, 2240, 2800, 7000	112.5 [4.43]
1600, 5120, 6400, 16000	227.7 [8.96]

### Torsion

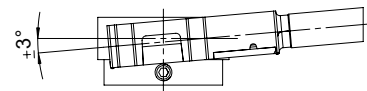

### Offset

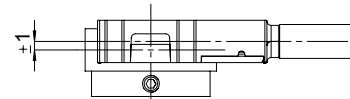

### Tilting

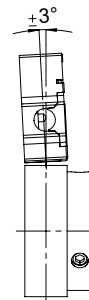

**Warning: When mounting the sensor head, please ensure its correct orientation to the magnetic ring!**

1) Shield is attached to connector housing.

# Bearingless encoders

**Incremental, large hollow shaft magnetic**

**RLI200 (hollow shaft)**

**Push-pull / RS422**

**Dimensions**

Dimensions in mm [inch]

**Sensor head**

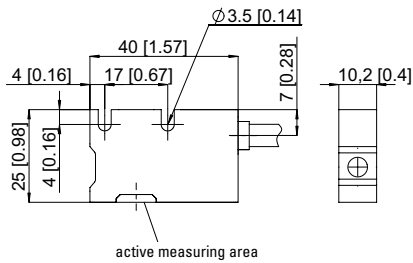

**Magnetic ring (press fit) for pulse rate 700, 2240, 2800, 7000**

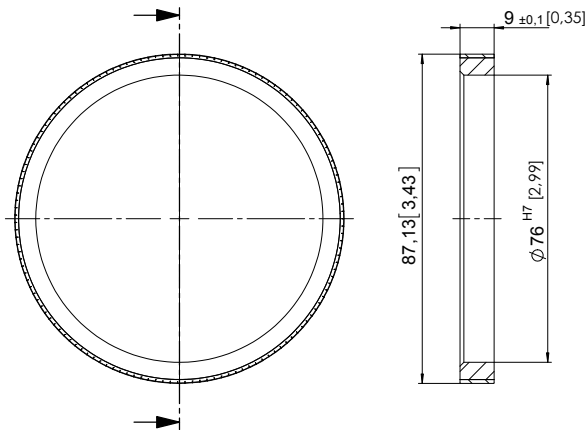

**Magnetic ring (press fit) for pulse rate 1600, 5120, 6400, 16000**

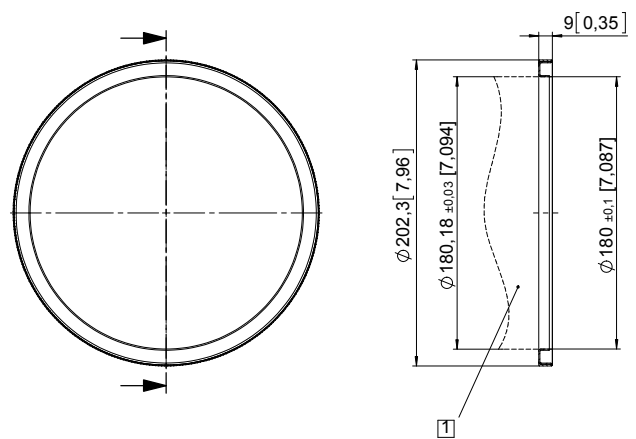

1 Customer shaft