

Manual

Encoders with
PROFIsafe interface



Table of Contents

1	Document	4
2	General Information	5
2.1	Target Group.....	5
2.2	Symbols used / Classification of the Warnings and Safety instructions	5
2.3	Transport / Storage	6
2.4	Relevant Standards	6
2.5	Safety Functions	6
2.5.1	Functional Specification	6
2.6	Safety Assessment	6
3	Product Description	8
3.1	Technical Data Sendix S58x8FS3	8
3.2	PROFINET IO Interface Description	9
3.3	PROFIsafe Interface Description	11
3.4	Supported Standards and Protocols	13
3.4.1	S58 Standards & Features	13
3.4.2	Optional Features	14
4	Installation	18
4.1	Mechanical Installation.....	18
4.2	Electrical Installation	18
4.2.1	General Information for the Connection.....	18
4.2.2	Terminal Assignment F58x8 / S58x8FS3	19
4.2.3	Network Topology	20
5	Commissioning and Operation	22
5.1	Function and Status LED.....	22
5.1.1	Overview of the Connectors and LEDs.....	22
5.2	Quick Start Guide.....	24
5.2.1	Configuration	24
5.2.2	Tool Calling Interface - TCI.....	45
5.2.3	Commissioning	49
5.2.4	Resetting to Factory Settings.....	52
5.3	Protocol Features.....	55
5.3.1	PROFINET.....	55
5.3.2	PROFIdrive	56
5.3.3	PROFIsafe	58
5.4	Configuration Parameters Description	59
5.4.1	Base Mode Parameter	59
5.4.2	I&M Data.....	78
5.4.3	Acyclic Data Transmission.....	80
5.5	Telegrams Description	81
5.5.1	Available Submodules / Telegrams	81

5.5.2	Submodule - StdTel36 (Encoder Profile V4.2).....	83
5.5.3	Submodule - StdTel37 (Encoder Profile V4.2).....	83
5.5.4	Submodule - StdTel81 (Encoder Profile V4.2).....	84
5.5.5	Submodule - StdTel82 (Encoder Profile V4.2).....	85
5.5.6	Submodule - StdTel83 (Encoder Profile V4.2).....	85
5.5.7	Submodule - StdTel84 (Encoder Profile V4.2).....	86
5.5.8	Submodule - StdTel86 (Encoder Profile V4.2).....	87
5.5.9	Submodule - StdTel88 (Encoder Profile V4.2).....	87
5.5.10	Telegram data.....	89
5.6	Features Description.....	97
5.6.1	Firmware update and reset.....	97
5.6.2	LLDP - Link Layer Discovery Protocol	100
5.6.3	MRP - Media Redundancy Protocol	101
5.6.4	Isochronous Mode IRT	102
5.6.5	Integrating an Encoder as a Technology Object.....	107
5.7	Diagnostics	111
5.7.1	Error	111
5.7.2	Warnings.....	113
5.8	Examples	113
5.8.1	Reading the I&M data	113
5.8.2	Replacement of a PROFINET encoder in the network.....	114
6	Annex	116
6.1	Requirements for an Encoder Evaluation Device	116
6.2	Definition Temperature Measurement	116
6.3	Scaling	116
6.4	Subnet mask in conjunction with the IP address	117
6.5	Conversion table Data types.....	119
6.6	Decimal / Hexadecimal conversion table.....	120
7	Contact.....	122
	Glossary.....	123

1 Document

This is the English translation of the original manual in German language.

Publisher	Kübler Group, Fritz Kübler GmbH Schubertstraße 47 78054 Villingen-Schwenningen Germany www.kuebler.com
Issue date	03/2024
Copyright	© 2024, Kübler Group, Fritz Kübler GmbH

Text sources

PROFIsafe – Profile for Safety Technology on PROFIBUS and PROFINET Technical Specification Version 2.6MU1 – Date: August 2018

PROFIsafe Systembeschreibung - Technologie und Anwendung Apr. 2016

SIEMENS -Totally Integrated Automation, Informationssystem - Informationssystem / PLC programmieren / Safety Safety- Projektieren und Programmieren / Safety Admin. Apr. 2022

Image sources

PROFIsafe – Profile for Safety Technology on PROFIBUS and PROFINET Technical Specification Version 2.6MU1 – Date: August 2018

PROFIsafe Systembeschreibung - Technologie und Anwendung Apr. 2016

Profile Drive Technology Encoder Profile Technical Specification for PROFIBUS and PROFINET Version 4.2 - Date March 2017

Code sources

Open Source Code:

mbedtls - Apache License 2.0 - License and copyright notice (<https://github.com/ARMmbed/mbedtls>)

mjson - MIT License - License and copyright notice (<https://github.com/cesanta/mjson>)

js-untar - MIT License - License and copyright notice (<https://github.com/InvokIT/js-untar>)

Legal Notices

All of the contents of this document are protected by the rights of use and copyrights of Fritz Kübler GmbH. Any duplication, modification, further use and publications in other electronic or printed media, as well as their publication in the Internet, even partially, is subject to the previous written authorization by Fritz Kübler GmbH.

The brand names and product brands mentioned in this document are trademarks or registered trademarks of the respective titleholders.

Subject to errors and changes. The stated product features and technical data shall not constitute any guarantee declaration.

2 General Information





Please read this document carefully before working with the product, mounting it or starting it up.

2.1 Target Group

The device may only be planned, mounted, commissioned and serviced by persons having the following qualifications and fulfilling the following conditions:

- Technical training.
- Briefing in the relevant safety guidelines.
- Constant access to this documentation.

2.2 Symbols used / Classification of the Warnings and Safety instructions

 DANGER	<p>Classification:</p> <p>This symbol, together with the signal word DANGER, warns against immediately imminent threat to life and health of persons.</p> <p>The non-compliance with this safety instruction will lead to death or severe adverse health effects.</p>
 WARNING	<p>Classification:</p> <p>This symbol, together with the signal word WARNING, warns against a potential danger to life and health of persons.</p> <p>The non-compliance with this safety instruction may lead to death or severe adverse health effects.</p>
 CAUTION	<p>Classification:</p> <p>This symbol, together with the signal word CAUTION, warns against a potential danger for the health of persons.</p> <p>The non-compliance with this safety instruction may lead to slight or minor adverse health effects.</p>
ATTENTION	<p>Classification:</p> <p>The non-compliance with the ATTENTION note may lead to material damage.</p>

NOTICE	Classification:
	Additional information relating to the operation of the product, and hints and recommendations for efficient and trouble-free operation.

2.3 Transport / Storage

Check the delivery immediately upon receipt for possible transport damages. If you do not mount the device immediately, store it preferably in its transport package.

The device must be stored at a dry and dust-free location, in compliance with the technical data, see chapter Technical Data.

2.4 Relevant Standards

The safety assessment of the encoder is based on the following standards and safety classes:

Relevant standards	Safety Integrity Level (SIL) according to EN 61800-5-2, EN 62061
	Performance Level (PL) according to EN ISO 13849-1

2.5 Safety Functions

The encoder can be used to support safety sub-functions in accordance with EN 61800-5-2 with reference to speed, direction of rotation, standstill and relative position, for example:

- SS1, SS2, SOS, SLS, SSM, SSR, SDI, SLA, SAR, SLI
- SSV, SAP, SAV

2.5.1 Functional Specification

Safe standstill

For safety subfunctions including standstill monitoring, the superordinate controller must monitor both the safe speed information and the safe position information.

Absolute position

The absolute position over several revolutions (multiturn) is measured in the encoder by a mechanical gear. This gear is limited to 4096 revolutions (total position range). Within this number of revolutions, the encoder can determine the position of the application at any time. Exceedance during operation by more than a quarter of the the total position range while the device is de-energized must be excluded on the application side.

2.6 Safety Assessment

You will find the characteristic safety values to be used for your own determination of the safety level of your machine in chapter Technical Data.

The characteristic safety values of all Kübler products can also be found in the Internet on the Kübler home page (www.kuebler.com/en/docu-finder) and in an XML software library provided by Kübler with all its products. It can be loaded in various programs used for calculating the overall safety.

3 Product Description

3.1 Technical Data Sendix S58x8FS3

Singleturn technology	Optical
Multiturn technology	Fully redundant magnetic gear
Singleturn resolution (MUR)	Max. 15 bits Safe / 24 bits Non Safe (default 13 bits)
Multiturn resolution (NDR)	Max. 12 bits Safe / Non Safe
Multiturn resolution (TMR)	Max. 27 bits Safe / 36 bits Non Safe (default 15 bits)
Scaling	Supports USF Scaling [► 116]
Output	PROFINET / PROFIsafe Ethernet 100Base-TX acc. to IEEE 802.x
Type of connection	Connector
Interface	PROFINET IO / PROFIsafe
Vendor ID	0x0198
Device ID	0x0002
Parameters memory	FRAM
Implemented profile versions	PROFIsafe Version V2.6 Encoder Profile Version V4.2 PROFIdrive Version V4.2
Implemented features	DCP IRT LLDP SNMP MIB-II LLDP-MIB PTCP MRP FSU I&M 0...3 Isochronous Mode Webserver
Implemented telegrams	Standard telegrams 81, 82, 83, 84, 86, 88 Standard safety telegrams 36 ,37 in Basic Protocol (BP) and Extended Protocol (XP) version
Classifications	RT CLASS 1 RT CLASS 2 (RT) RT CLASS 3 (IRT) Conformance Class C Application Class 6 Encoder Class 4 NetloadClass III
Min. cycle time PROFINET	Min. device interval = 500 µs
Min. cycle time PROFIsafe	Min. device interval = 4 ms

Mechanical characteristics for the Sendix S58xx Encoders

Maximum rotational speed IP67	9000 min ⁻¹ , (for short periods – 10 min) 6000 min ⁻¹ (continuous operation)
Starting torque (at 20 °C) IP67	< 0.01 Nm
Mass moment of inertia Shaft version Hollow shaft version	3,0 x 10 ⁻⁶ kgm ² 6 x 10 ⁻⁶ kgm ² (MT)
Permissible shaft load radial axial	80 N 40 N
Protection level acc. to EN 60529 Housing side Shaft side	IP65 / IP67 IP65 / IP67
Ambient temperature range	-40 °C ... +80 °C Definition Temperature Measurement [▶ 116]
Materials Shaft/hollow shaft Flange Housing	Stainless steel Aluminum Aluminum
Shock resistance according to EN 60068-2-27	1000 m/s ² , 6 ms
Vibration resistance according to EN 60068-2-6	220 m/s ² , 200 Hz ... 2000 Hz

Electrical characteristics

Supply voltage	10 ... 30 V DC	
	according to UL 1310	Class 2
Current consumption (no load)	10 V DC	250 mA
Protection class	according to EN 61140	III (PELV)
Smallest safe measuring step	158.4 arcsec (0.044° / 4 increments)	
Lowest safe rotational speed	4 rpm ($\sigma_v < 0,5\%$)	

Safety classification	PLe / SIL3 acc. to ISO 13849-1
Safety category	Fully redundant 2-channel structure (cat. 3)
Diagnostic coverage	>99%
PFh value	9.54 x 10 ⁻¹⁰

3.2 PROFINET IO Interface Description

PROFINET is a mechanism for exchanging data between controllers and devices. Controller may be a PLC, a DCS or a PAC (Programmable Logic Controller, Distributed Control System, or Programmable Automation Controller). Devices may be any I/O block, vision system, measuring sensor, RFID reader, drive, process instrument, proxy or even other controllers.

PROFINET exchanges data quickly and in a deterministic manner. The required speeds vary according to the application. Update can take place in hundreds of milliseconds, a few milliseconds or even < 1 millisecond. Determinism means that the messages arrive at a defined point of time, when they have to.

Other protocols are not as deterministic. For example Modbus TCP uses TCP, which implies that a virtual connection is established between both devices and that all messages must pass through the TCP/IP stack. EtherNet/IP uses UDP, so that messages must pass through the UDP/IP stack. The time to pass the stack is variable and reduces the determinism, in addition to the speed loss. EtherCAT is deterministic, but it is a closed network.

PROFINET exchanges data, including quality and asset management information. The protocol is standardized in IEC 61158 and IEC 61784.

Conformance Classes

PROFINET defines three conformity classes that build up on one another, which are oriented at typical applications (Figure below):

- CC-A provides basic functions for PROFINET IO with RT communication. All IT services can be used without restrictions. Typical applications can be found e. g. in the enterprise automation systems. For this class, wireless communication is specified.
- CC-B extends the concept with the network diagnostics through IT mechanisms and topology information. The system redundancy function, which is important for process automation, is included in an extended version of CC-B called CC-B(PA).
- CC-C describes the basic functions for devices with hardware-based band width reservation and synchronization (IRT communication) and is thus the basis for isochronous applications. The conformity classes also serve as the basis for certification and for the wiring guidelines.

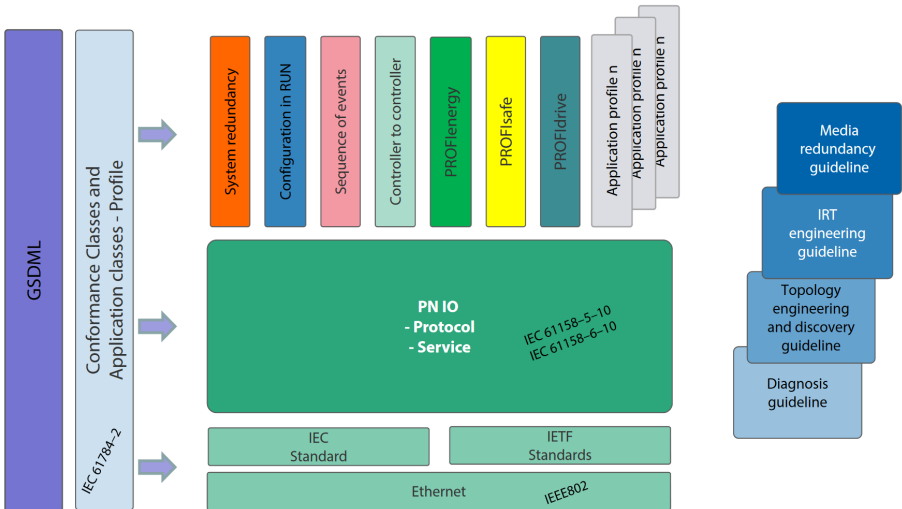

IMG-ID: 108020747

Parameterizing

Parameterizing requires the GSD (General Station Description) files of the field devices to be configured. The XML-based GSDML describes the features and functions of the PROFINET IO field devices. It contains all data relevant for engineering and data exchange with the field device. The field device manufacturer must provide the XML-based GSD in compliance with the GSDML specification.

Addressing

In a PROFINET IO system, every field device is given a symbolic name, which clearly identifies the field device within this IO system. This name is used to correlate the IP address and the MAC address of the field device. The DCP (Discovery and basic Configuration Protocol) is used for this purpose.

Every PROFINET device is addressed by means of its worldwide unique MAC address. This MAC address includes a company code (bit 24 47) as the OUI (Organizationally Unique Identifier) and a consecutive number (bit 0 23). An OUI allows identifying up to 16,777,214 products of a single manufacturer.

Optionally, the name can also be assigned automatically to the IO device by the IO controller by means of a specified topology, based on neighborhood detection. Here the IP address is assigned on the basis of the device name via the DCP protocol. Since DHCP (Dynamic Host Configuration Protocol) is internationally widespread, PROFINET has provided an optional address setting via DHCP or via manufacturer-specific mechanisms. The addressing options supported by a field device are defined in the GSDML field for the concerned field device.

Source: PROFINET System Description Technology and Application 10.2014

3.3 PROFIsafe Interface Description

PROFIsafe is based on the existing PROFINET protocol and extends it with various safety-oriented functional features. This represents a shift in the approach used until now for the functional safety in automation. Generally, hardwired systems in redundant design were considered safe.

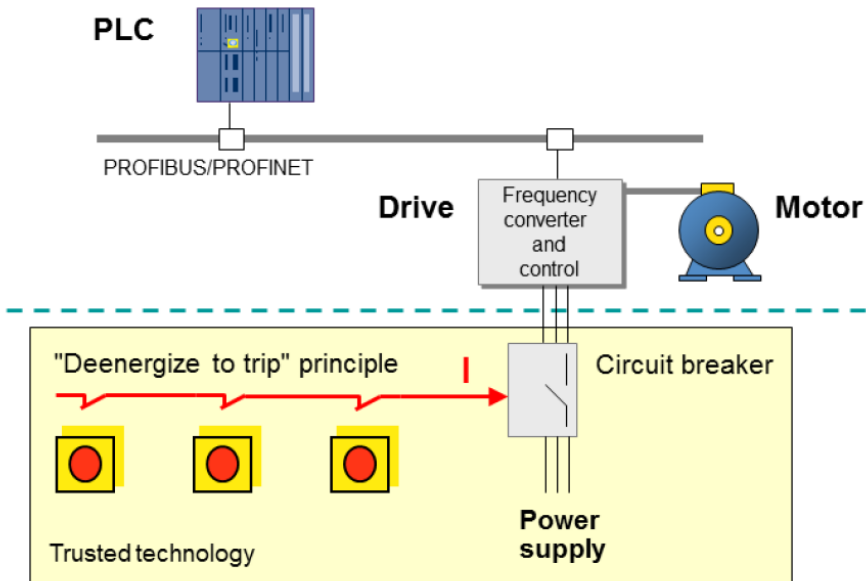

PROFIsafe implements all advantages of the Ethernet technology for safety-oriented applications. The hardware redundancy of hardwired components is no longer necessary. This is described in PROFIsafe standard IEC 61784-3-3, which in turn refers to various other safety standards. Only F-devices and F-hosts certified according to IEC 61508 may be used in PROFINET networks.

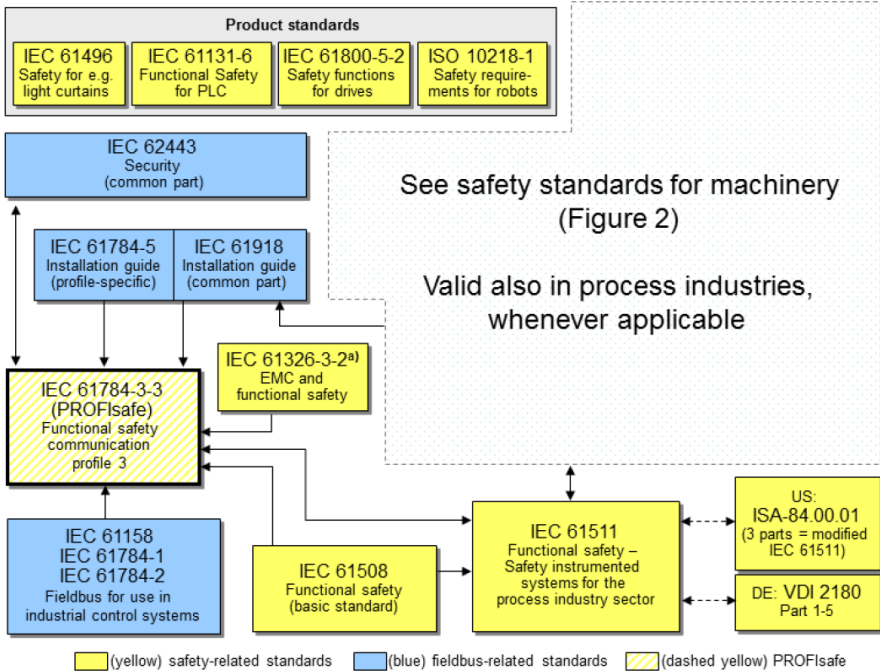

^{a)} For specified electromagnetic environments; otherwise IEC 61326-3-1 or generic IEC 61000-6-7

PROFIsafe mainly uses the “Black Channel” approach, according to which the safety layer is based on the PROFINET standard protocol.

In compliance with IEC 61508 or PL “e” / Category 4 according to ISO 13849, the PROFIsafe protocol can be used for safety-oriented applications up to SIL3.

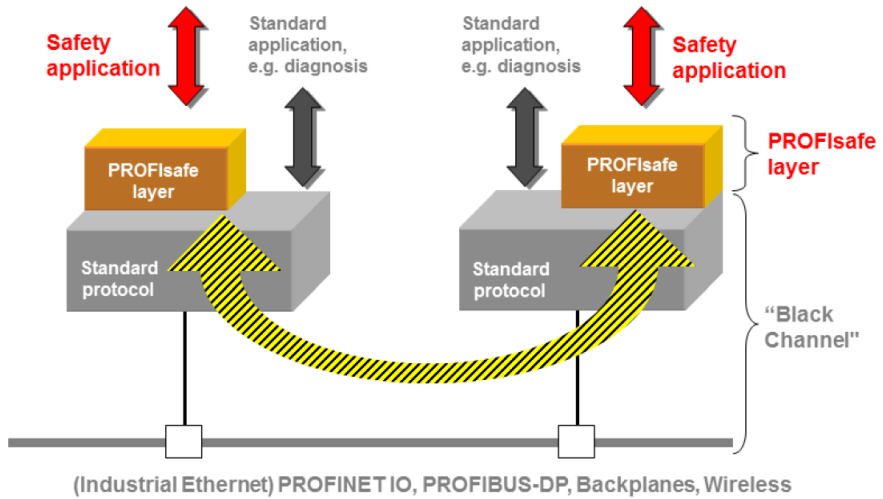

The safety requirements are achieved through extended mechanisms such e.g. the numbering of F-messages (compliance with the sequence), extended identification between emitter and receiver (“authentication”), as well as through data integrity checking (32-bit CRC generator polynomial) including the acknowledgment.

Furthermore, the F-host services and the F-device services handle the exchange of F input and output data. “F” means here Failsafe. This means that the values are checked with special care and must be failsafe especially in their initial state. Besides, all settings are managed via F-parameters. These must be acknowledged by the user for every application.

In addition to the F-parameters, there are also so-called “iParameters“, which represent the individual parameters depending on the characteristics of the F-devices in the network. Also these are handled from a safety-related point of view through a defined CRC.

3.4 Supported Standards and Protocols

The PROFINET standards and features implemented in the device are listed below:

3.4.1 S58 Standards & Features

- RT_CLASS_1
- RT_CLASS_2 (RT)
- RT_CLASS_3 (IRT)
- DCP
- RTA
- LLDP
- SNMP
- MIB-II
- LLDP-MIB

- PTCP
- MRP
- FSU
- Conformance Class C
- Application Class 6
- Encoder Class 4 / S2
- NetloadClass III
- I&M 0...4
- Min. DeviceInterval Non Safe= 250 µs
- Min. DeviceInterval Safe= 2 ms
- Isochronous Mode
- Encoder profile V4.2
- PROFIsafe profile V2.6
- PROFIdrive profile V4.2
- Basic web server

Conformity

EN 61000-4-2 :2001

EN 61000-4-3 :2006

EN 61000-4-4 :2005

EN 61000-4-5 :2007

EN 61000-4-6 :2008

EN 61000-4-7 :2004

EN 61000-6-4 :2007

EN 61000-6-2 :2006

EN 61800-5-2

EN 62061

EN 61508

EN 13849-1

En 13849-2

3.4.2 Optional Features

PROFINET defines features that must not be mandatorily implemented (optional features).

<i>NOTICE</i>	Observe the specific implementation
	The overview provides information about whether the feature is implemented in the device. This however does not mean that the feature is implemented in the same way in every device The specific implementation can be found in the description in the following pages.

Optional PROFINET features	Description	Sendix S58x8 (Encoder profile 4.2)
Network Redundancy with Media Redundancy Protocol (MRP)	The Media Redundancy Protocol provides network ring redundancy for PROFINET IO real-time networks	Implemented
System Redundancy	Allows a primary and backup controller for redundant applications with PROFINET	Implemented
Device Redundancy	Allows a device to have several interfaces, including PROFINET redundancy	Not implemented
Shared Device	Distribution of the device functions over different controllers	Not Implemented
Shared Inputs	Multiple access to inputs by different controllers	Not implemented
Device Access	Allows reading or writing parameters by means of a configuration tool	Not Implemented
Supervisor Access	Allows an IO supervisor to take in charge an IO device to check inputs, outputs and device functions	Implemented
Extended Device Information (Identification & Maintenance Records 1-3)	Extended device information (site description, mounting date, etc.)	Implemented
Direct data exchange / Multicast Communication Relation (MCR)	A multicast communication relation allows several devices to communicate by direct data exchange	Not implemented
Simple Network Management Protocol (SNMP)	Allows reading simple network management protocols and topology information	Implemented
Simple device replacement	In the event of device failure and replacement, allows a controller to name automatically a replaced IO device	Implemented
Configuration in Run (CiR)	Allows configuring and setting a device even while the controller / the PLC is in "Run" mode	Not implemented
Time Stamping	Allows using time stamps based on a real-time clock	Not implemented
Fiber Optic Cable diagnostics	The fiber optic cable diagnostics offer improved diagnostics for the maintenance in the event that the cable loses signal strength over time	Not implemented
Fast Startup (FSU)	Fast device start-up after the power cycle for specific applications (e. g. tool changers)	Not implemented (not permitted for F devices)
Isochronous Real Time (IRT)	The isochronous real-time allows synchronous communication with bandwidth reservation and scheduling up to 250 µs with < 1 µs jitter for motion control applications	Implemented

Optional PROFINET features	Description	Sendix S58x8 (Encoder profile 4.2)
Dynamic Frame Packing (DFP)	Dynamic frame packing with IRT is optimized for line structures and allows 31.25 µs update times for high-speed motion control applications	Not available yet
IRT with Media Redundancy for Planned Duplication (MRPD)	Network media redundancy for planned duplication for IRT systems – Constant two-way transmission	Not implemented
Tool Calling Interface (TCI)	Tool calling interface used for calling a device-specific engineering tool	Implemented
Individual Parameter Server (iPar)	Individual parameter server (iPar) for automatic parameter assignment of devices (e. g. for safety)	Implemented
Application and Device Profiles	Special application/device profiles for specific applications (e. g. safety, energy, drives) or device data sets for specific device types (e. g. encoders)	Implemented
Manufacturer Specific Alarms	Manufacturer-specific PROFINET diagnosis alarms (e.g. redundant power supply error, manufacturer-specific error code)	Implemented

4 Installation

NOTICE	Observe the operation manual
	Installation instructions can be found in the relevant operation manual.

See document: [R60091](#) - S58xxFS PROFINET with PROFIsafe

4.1 Mechanical Installation

NOTICE	Mechanical Installation
	The mechanical installation is described in the operation manual of the product. It is enclosed in printed form with the product and it can be downloaded from the product website. Contact [▶ 122]

4.2 Electrical Installation

4.2.1 General Information for the Connection

ATTENTION	Destruction of the device
	Before connecting or disconnecting the signal cable, always disconnect the power supply and secure it against switching on again.
NOTICE	General safety instructions
	Make sure that the entire system is in a de-energized state during electrical installation.
NOTICE	No open cable wires
	<p>Connect all required cable wires / connectors before commissioning. Insulate individually all unused ends of the output signals to avoid short-circuits.</p> <ul style="list-style-type: none"> • Electrostatic discharges at the contacts of the connector or at the cable ends could damage or destroy the device. Take appropriate precautionary measures.
NOTICE	Traction relief
	Always mount all cables with traction relief.

NOTICE	Use shielded data lines
	Use exclusively shielded data lines to comply with the EMC interference immunity requirements in force for interference emissions and external interference.



4.2.2 Terminal Assignment F58x8 / S58x8FS3

4.2.2.1 Terminal Assignment

The encoder has three connectors, two of them are the two Ethernet ports.

The central connector is the power supply of the encoder. The power supply connector is an A-coded M12 plug.

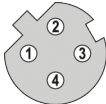
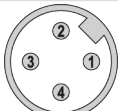
Both Ethernet connectors are D-coded M12 sockets. The assignment of the signals to the pins is described in the table below.

3x M12, 4-pole					Connector
Link 1 - Ethernet Port IN / OUT					
Signal	TxD+	RxD+	TxD-	RxD-	
Pin	1	2	3	4	
Voltage supply					
Signal	+ V	-	0 V	-	
Pin	1	2	3	4	
Link 2 - Ethernet Port IN / OUT					
Signal	TxD+	RxD+	TxD-	RxD-	
Pin	1	2	3	4	

The two external encoder connectors “PORT 1” and “PORT 2” are used for the Ethernet communication. One of the two ports is sufficient for a star structure. Both ports are required for a line or ring structure. In principle, the data ports are equivalent and can be chosen freely.

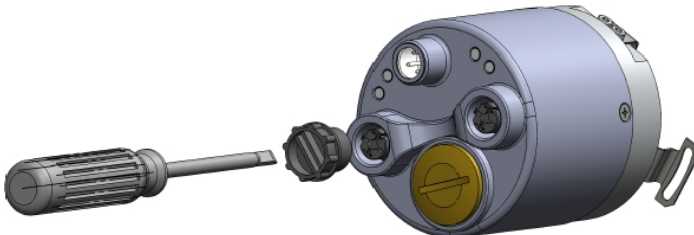

NOTICE	M12 connector cover
	Both Ethernet ports are provided with a plastic cap. If only one of both ports is to be used, the cap of the other port must be tightened at a torque of 1 Nm [0.74 ft-lb] to ensure the IP protection level.

Signal assignment of an M12 to RJ45 cable

M12 to RJ45 direct

Signal	M12 Pin	RJ45 Pin
TxD+	1	1
TxD-	3	2
RxD+	2	3
RxD-	4	6

4.2.3 Network Topology

Network topologies result from the functional requirements imposed on the respective network. However, network planners must also consider aspects such as management, performance, spatial environment, safety, maintenance and savings potential. Thus, the network topology is in practice always a compromise resulting from very different considerations.

PROFINET basically allows realizing any industrial network topology. There are essentially three patterns used to arrange devices in a network: the line, the star and the ring. Each of these three basic physical topologies in turn includes the smallest topology possible: the point-to-point topology between two participants.

- In the line topology, all participants are interconnected by means of a common transmission medium. This medium is called bus, so this topology is also called bus topology.
- The star topology includes point-to-point connections between a central network participant and all others, which are arranged in star with respect to it. The transmission medium runs point-to-point between them, resulting in a star structure.
- For the ring topology, all network participants are connected via two points. This means that every participant maintains two point-to-point connections with other participants, resulting in a circular structure.

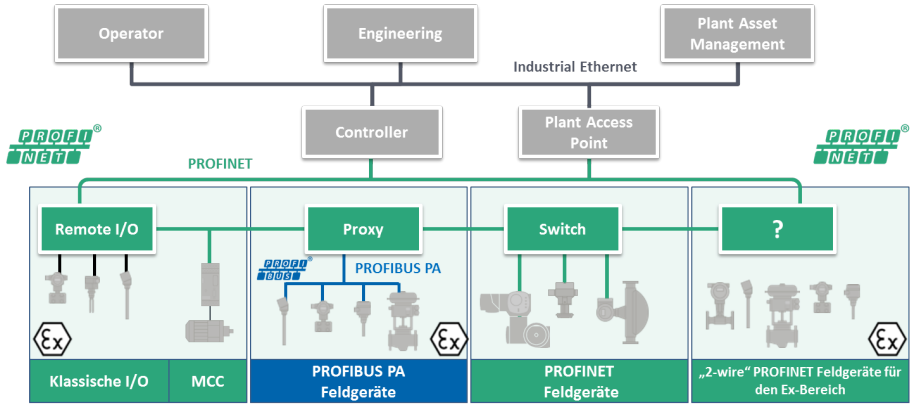

IMG-ID: 9007199362890507

The basic logical topologies can be assigned to these three basic patterns.

- In the line topology, the data sent by a network participant is broadcast over the whole transmission medium. Thus, when a network participant is sending, no other participant can send without leading to data collision.
- In the star topology, every connection between the central network participant and another participant consists in two lines - one to send, one to receive. The sent signal of a network participant is sent via the central network participant to all others.
- In the ring topology, a network participant is only allowed to send when he receives the transmission authorization (token) circulating in the ring. Data prepared for sending is added to the token and transmitted in the ring from participant to participant until the target participant receives it.

NOTICE	Topology and line length
	Independently of the chosen topology, the length of the line between the single PROFINET devices shall in no case exceed 100 meters. In the event of line lengths exceeding 100 meters, the single devices must be coupled through suitable switches.

5 Commissioning and Operation

! DANGER



Risk of injury due to rotating shafts

Hair and loose clothing can be caught by rotating shafts.

- Prepare all work as follows:
 - ⇒ Switch the operating voltage off and stop the drive shaft.
 - ⇒ Cover the drive shaft if the operating voltage cannot be switched off.

5.1 Function and Status LED

5.1.1 Overview of the Connectors and LEDs



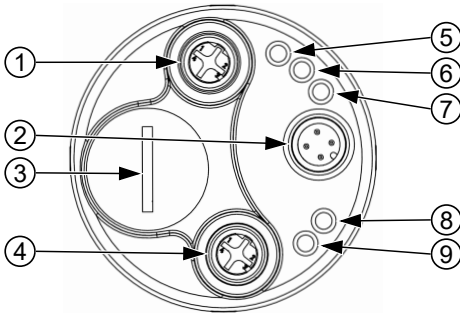









The encoder has five LEDs (No. 5 – 9).









IMG-ID: 54043195769897867

1	Ethernet port – Link 2	5	Link 2	9	Link 1
2	Supply voltage	6	BF – Bus Failure		
3	Cover screw	7	SF – System Failure		
4	Ethernet port – Link 1	8	ENC – Encoder		

The status of the LEDs marked with “-” is irrelevant.

Display	LINK 1	LINK 2	ENC LED	SF LED	BF LED	Description	Measures
ENC LED Green constantly on	-	-				Operational. The whole process data traffic is active. Actual and setpoint values are transmitted SF and BF LED off No errors are present.	
ENC LED Green flashing 1.0 Hz	-	-		-	-	Firmware update in progress.	<ul style="list-style-type: none"> • Wait until firmware update is complete. • In no case switch off the power supply!
ENC LED together with LINK 1/2 LED flashing				-	-	Data transmission active (ACTIVITY) LINK1, LINK2 or both may flash.	
ENC LED and SF LED Red constantly on	-	-			-	Error active.	<ul style="list-style-type: none"> • See SF LED
ENC LED Flashing 1.0 Hz together with SF LED constantly on	-	-			-	PROFIsafe passivated and/ or warning active.	<ul style="list-style-type: none"> • Depassivate the device. See Controller configuration [► 32] • Check the warning in the online diagnostics
SF LED constantly on	-	-	-		-	No PROFINET link established: Position error, temperature limit value exceeded, startup error, watchdog or process data interface between microcontroller and slave.	<ul style="list-style-type: none"> • Check the wiring • Switch on the PN controller (PLC) • Set the device name as in "Hardware configuration" • Check the "hardware configuration"

Display	LINK 1	LINK 2	ENC LED	SF LED	BF LED	Description	Measures
SF LED flashing	-	-	-	  	-	Device passivated.	<ul style="list-style-type: none"> Perform user acknowledgment to depassivate.
BF LED constantly on	-	-	-	-		No PROFINET link established.	<ul style="list-style-type: none"> Check the wiring Switch on the PN controller (PLC) Set device name (again) Check the hardware configuration
BF LED flashing 1.0 Hz	-	-	-	-	  	PROFINET link established, but the user parameter data is missing (BF00 telegram).	<ul style="list-style-type: none"> Use the proper GSD file "Insert" the submodule in the subplot

5.2 Quick Start Guide

5.2.1 Configuration

5.2.1.1 Configuring the Network

NOTICE	<p>Consider the project design software</p> <p>The steps below refer to project design in SIMATIC TIA Portal. Deviations in the description may occur, depending on the software.</p>
NOTICE	<p>Installation of the device description file</p> <p>During installation, the corresponding .bmp file must be in the same folder as the GSDML /.xml file.</p>

PROFIsafe integration

- ✓ Make sure that a static IP address has been assigned to the computer used for project design.
- ✓ The .xml file corresponding to the device must previously be downloaded from the website and decompressed in a folder.
 - a) Start SIMATIC TIA Portal and open the project (with the CPU or PN controller connected). Select "Project view".
 - b) Select "Manage general station description files (GSD)".

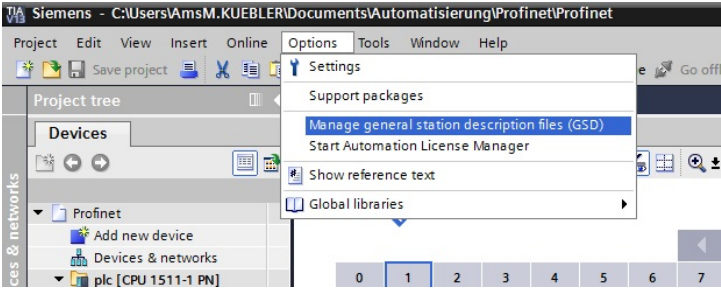

IMG-ID: 108551563

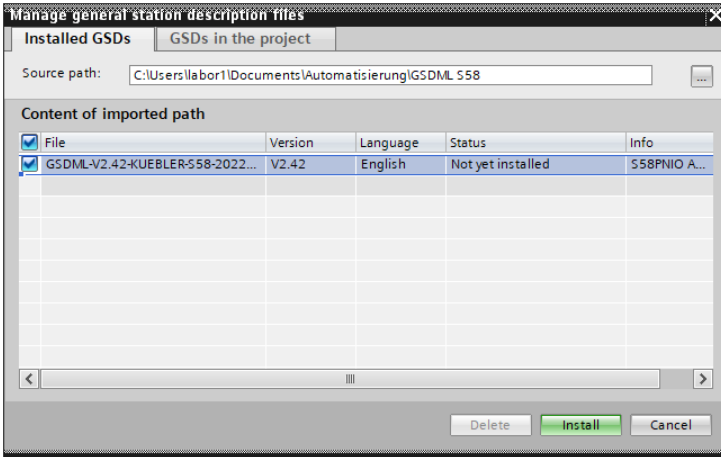

IMG-ID: 236750475

- c) Select the appropriate GSDML and confirm with "Install".
 ⇒ The GSDML file is added to the library.

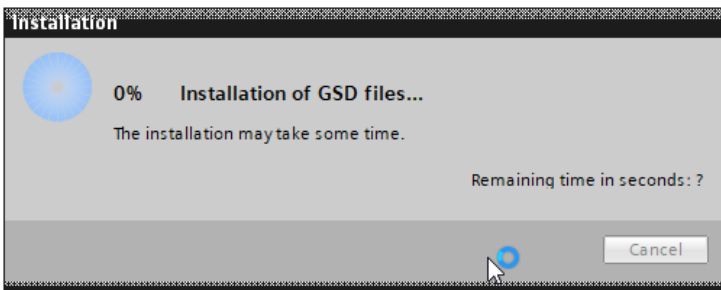

IMG-ID: 236752395

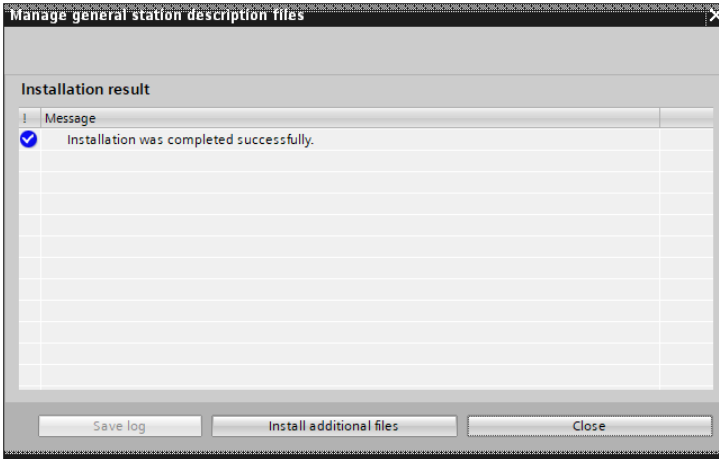

IMG-ID: 236754315

- d) Double-click on "Project tree/Project.../Devices & Networks" to call up the "Network view".
- e) In the "Hardware catalog", click in "Other field devices" and follow the path "/ PROFINET IO / Encoders/Fritz Kuebler GmbH / Absolute-Encoder / S58x8FS3".
- f) Use the mouse cursor to drag the module in the "Network view".
 - ⇒ This creates an object that represents the encoder.

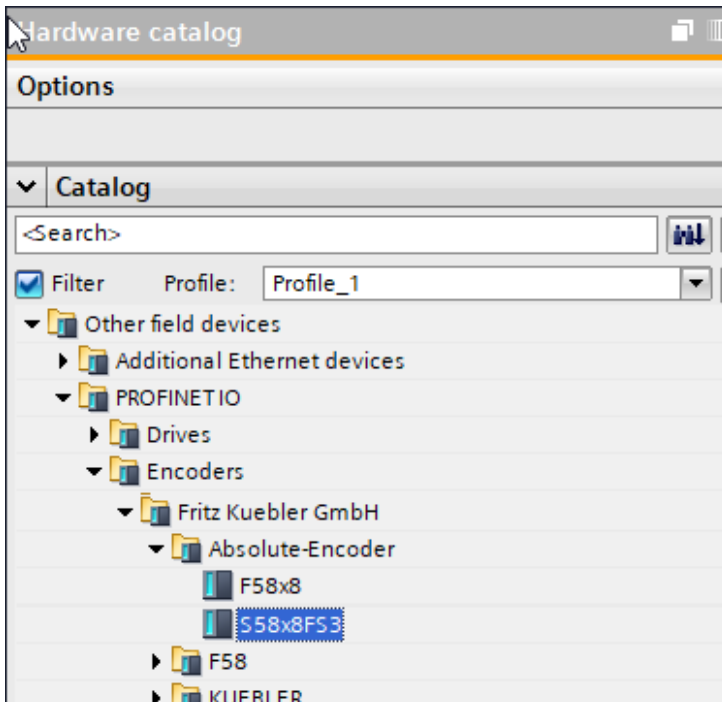

IMG-ID: 284299275

- g) Connect the encoder to your PLC through the desired network.
 ⇨ The encoder is now connected to the PLC on the network side.

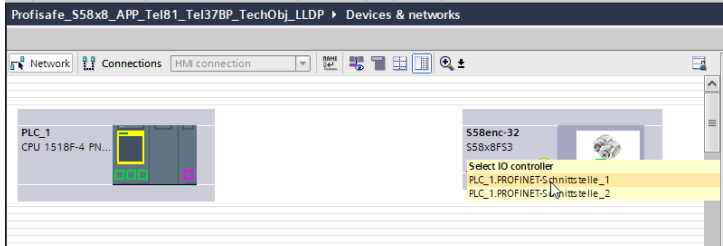

IMG-ID: 284254859

5.2.1.2 Configuring the Encoder

Saving the device name and submodules

In order to allow convenient and fast parameterizing, PROFINET uses device names instead of the IP address. In the event of a F-device, the F-destination address must be stored for the concerned device in addition to the device name. This address must necessarily be assigned in 2 different ways.

- Via the module parameters
- Via the device name

NOTICE	<p>The F-destination address must be biunique</p> <p>Make sure that the F-destination address is always biunique. This means that it may be present only once in every network and per controller. The value in the module parameters must correspond exactly to the value attached to the PROFINET device name.</p>
---------------	---

- ✓ Make sure that the encoder has been properly added to the network view.
 - a) Mark the added encoder.
 - b) Click on tab "Device overview". Input here a meaningful device name and assign the F-destination address by adding it as the last digits of the device name, without spaces or special characters.

Module	Rack	Slot
558enc-32	0	0
▶ PN-IO	0	0 X1
▼ PNO Encoder Profile_1	0	1
MAP Parameter Access	0	1 1
Standard Telegram 81	0	1 2
Standard Telegram 37 (BP)	0	1 3
	0	2

IMG-ID: 284256779

NOTICE**Rules for the PROFINET device name**

The maximum value for the F-destination address is 65534. The value 0 is invalid.

The F-destination address is evaluated starting from the last character of the PROFINET device name up to the first recognized non-digit character.

The device name is subject to the following restrictions: The F-destination address must be written directly and without special characters or spaces behind the name.

Limited to 240 characters in total (lowercase letters, digits, hyphen or point).

The length of a name component within the device name, i.e. a character string between two points, cannot exceed 63 characters.

No special characters such as umlauts, brackets, underscore, slash, space, etc.

The hyphen is the only special character allowed.

The device name cannot begin or end with the "-" character.

The device name cannot begin with digits.

The device name cannot be in the form n.n.n.n (n = 0, ... 999).

The device name cannot begin with the string "port-xyz" or "port-xyz-abcde" (a, b, c, d, e, x, y, z = 0, ... 9).

c) Subsequently, click on "Assign device name" to assign the device name to the device.

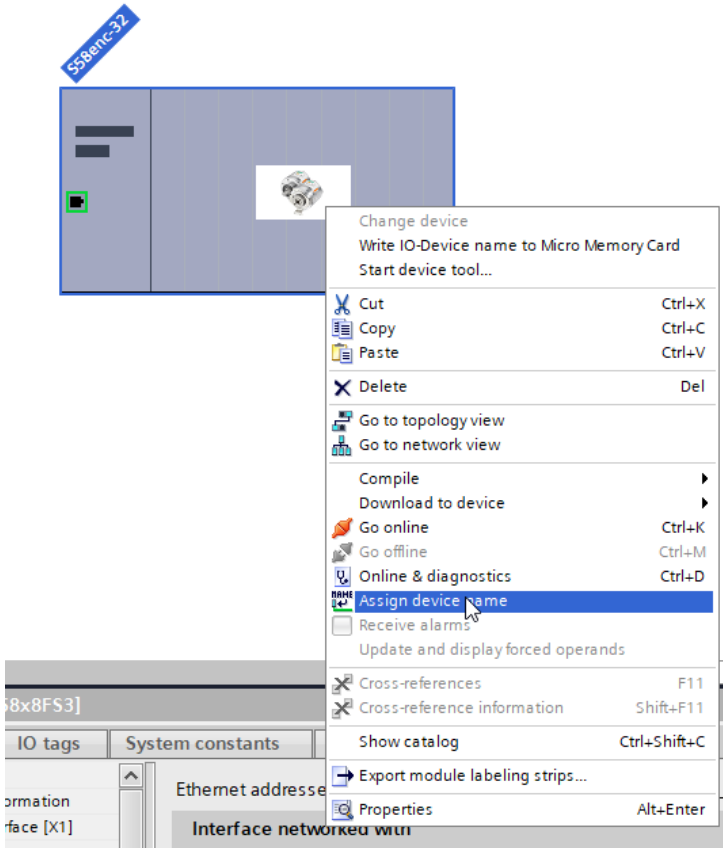

IMG-ID: 284258699

Example of a valid device name with F_Dest_Add 123:

- S58Enc123
- S58Enc-123

d) According to the required "Input/output data format", drag one of the modules from the hardware catalog in the "Device overview" to "Slot 1" of the encoder. StdTel36 and StdTel81 are already factory-preset at both module positions.

⇒ The submodules are now stored.

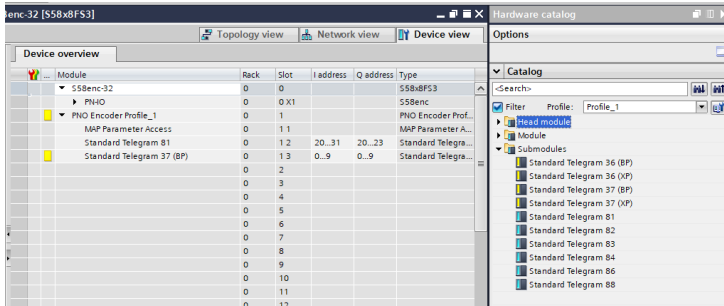

IMG-ID: 284260619

Storing the F and i parameters

Besides the F-parameters, the iParameters (individual parameters) are arranged on the general module level. These vary according to the application and must be defined by the user.

Basically, all parameters used for the configuration of the safety functions of an encoder represent safety-relevant values.

Therefore, these values are referred to as F-parameters (Failsafe related parameters). The F-parameters can be found within the used telegram.

If the parameters need to be adapted, this must always be confirmed by the user by means of a checksum (CRC).

- Click on the respective used safety telegram.
- Select item "Module parameters" in tab "Properties" and set the module parameters as required.

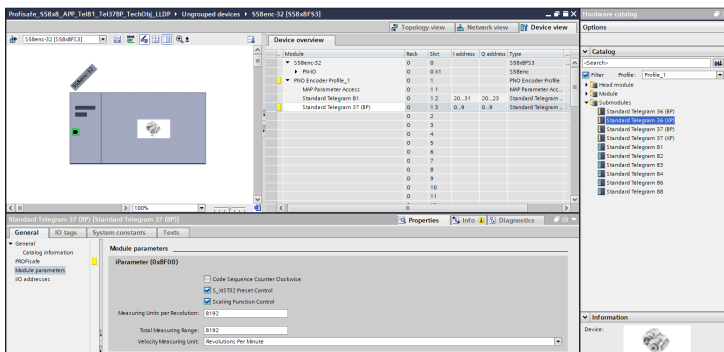

IMG-ID: 284262539

- Select item "PROFIsafe" in tab "Properties" and set the F-destination address. This address must correspond exactly to the figure added to the device name.

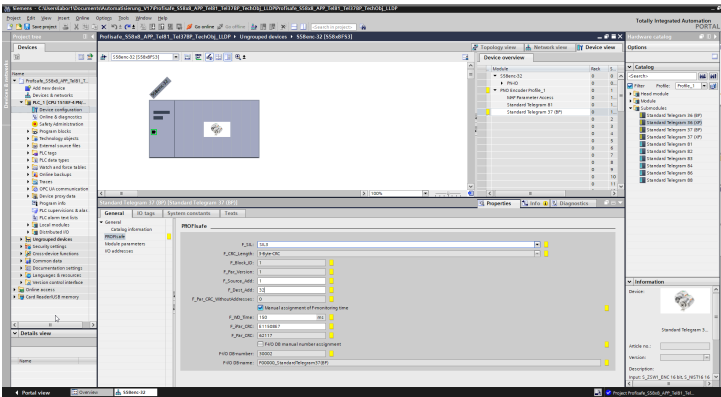

IMG-ID: 9007199539005451

d) Now set the remaining F-parameters as required.

e) Finally, input the CRC for the F-parameters.

⇒ The CRC must be calculated using the available TCI program Tool Calling Interface - TCI [45]

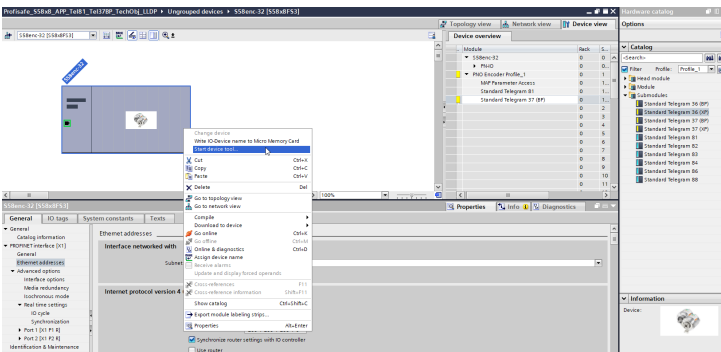

IMG-ID: 284268299

NOTICE

Observe factory settings

For multiturn encoders, the factory setting of the TMR value is 8192, which corresponds, with MUR 8192, to a singleturn encoder. This is due to the fact that both encoders are integrated using the same GSDML file. Therefore, for a multiturn encoder, this value must be modified by the user in any case.

Submodules StdTel36 and StdTel81 are factory-preset

5.2.1.3 Controller configuration

Storing the safety parameters

 WARNING	<p>Consequences of improper parameterizing</p> <p>During commissioning and after any parameter change, all functions must be checked by a secured test run.</p>
NOTICE	<p>F-signatures</p> <p>The F-signatures of the safety administration provide information on the revision status of the safety program. There are basically three F-signatures relating to the following:</p> <p>Overall F-signature: this signature changes at every change of the failsafe project data. It includes the signatures described below:</p> <p>Overall F-SW signature: this signature changes in the event of changes at the safety program.</p> <p>Overall F-HW signature: this signature changes in the event of changes at the failsafe HW configuration.</p> <p>As soon as the controller switches to the “online” status, the offline condition is compared with the online condition. Existing deviations are displayed when establishing the link.</p>

Basic controller parameters must be set up for safety-oriented operation. If this has not been done yet, the following settings can be used to start the operation with the measuring system.

- ✓ Make sure that the controller has been integrated properly in the project.
- a) Open the network topology overview and select the controller.

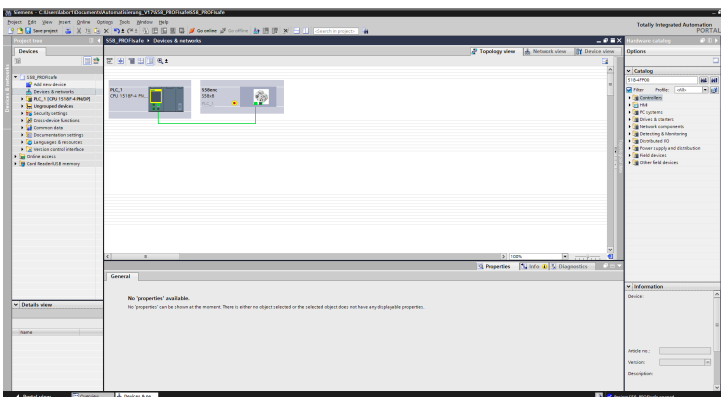

IMG-ID: 236767755

- b) Navigate to the Properties and open the dialog “PROFINET interface/Ethernet addresses”. If necessary, define the correct subnet and store a meaningful IP address for the controller.

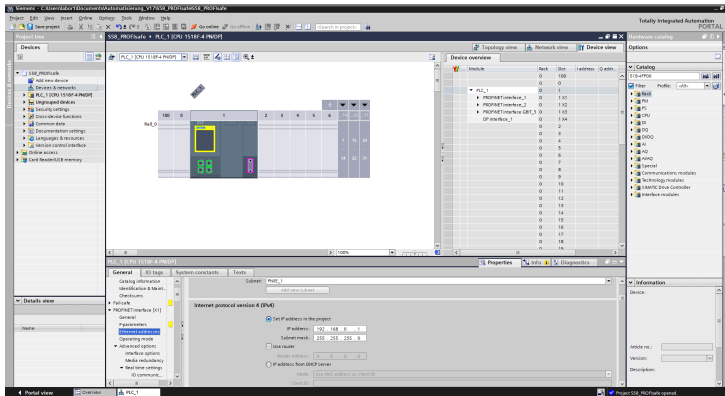

IMG-ID: 2367769675

- c) Define the required security level under “Protection & Security”.

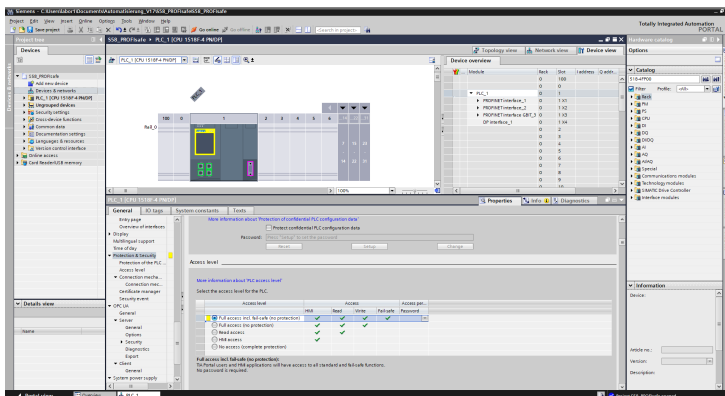

IMG-ID: 236771595

- d) The controller automatically creates the blocks required for the safety program. However, the fail-safe must be activated in the F-CPU for this. For this purpose, select item “Fail-safe” and check the box “F-capability activated” if it is not already checked.

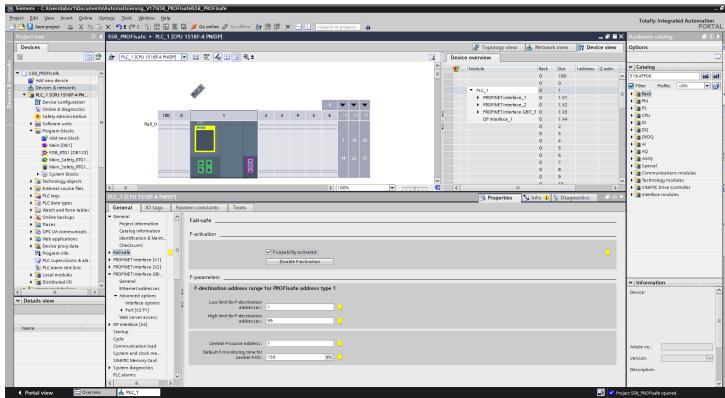

IMG-ID: 236773515

e) Item “Advanced options / Interface options” additionally allows activating the device replacement without exchangeable medium or the LLDP mode v2.2.

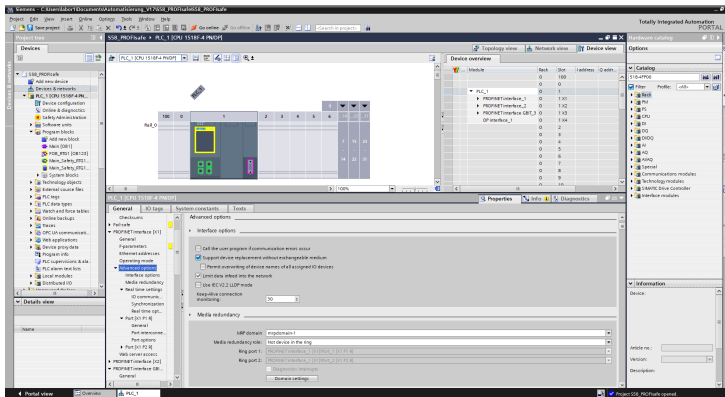

IMG-ID: 236779275

f) Set the required F-monitoring time under menu item “F-parameters”.

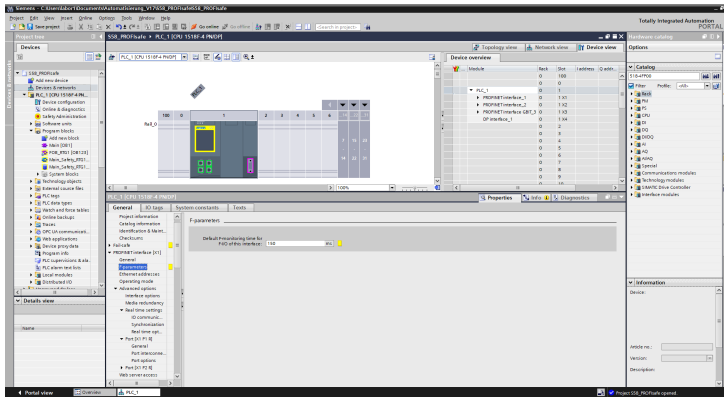

IMG-ID: 236777355

Store the parameters and data block for the F-runtime group.

NOTICE	<p>Marking the safety components of the controller</p> <p>All safety-relevant components of the controller are displayed with a yellow background. This relates both to the controller parameters and to the peripheral device parameters.</p>
---------------	---

First, the required settings for the F-runtime group are set.

- a) Select the planned controller in the project tree and navigate to item §Safety Administration§. Check the settings of the F-runtime group and adapt them if necessary. In this example, the default settings remain unchanged.

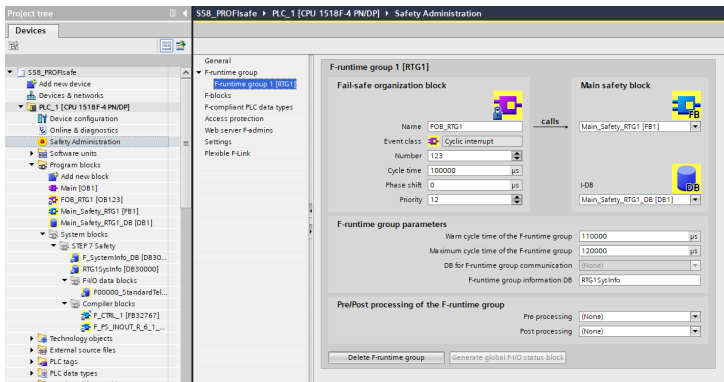

IMG-ID: 236788875

- b) Navigate to item “Access protection” and define a password for the controller if necessary.

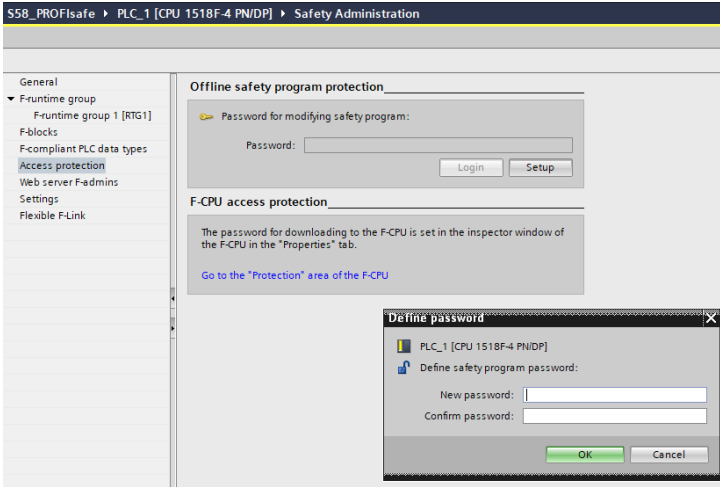

IMG-ID: 236790795

- c) Select item "Settings" and check the safety system version.
- d) If you want to have the possibility to force values at a later time during the installation of the system, we recommend selecting the setting "Safety mode can be disabled". This is necessary because the manual forcing of an output variable represents an intervention that is not considered in the safety sequence program and would therefore lead to an error. Therefore, define a meaningful period of time during which the safety operation is deactivated once.

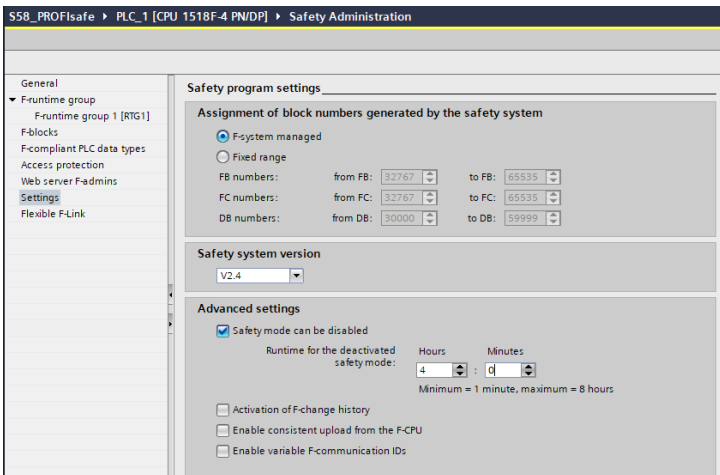

IMG-ID: 236792715

**WARNING****Manual intervention in the safety program**

The manual intervention in the safety program by setting the values of certain output variables is possible during the installation of the system, but it is not recommended.
Ideally, all safety functions can be tested with the safety sequence program.

Then the data block is added. This block is necessary to be able to manage the process input data of the measuring system.

- e) Select the integrated controller in the project tree.

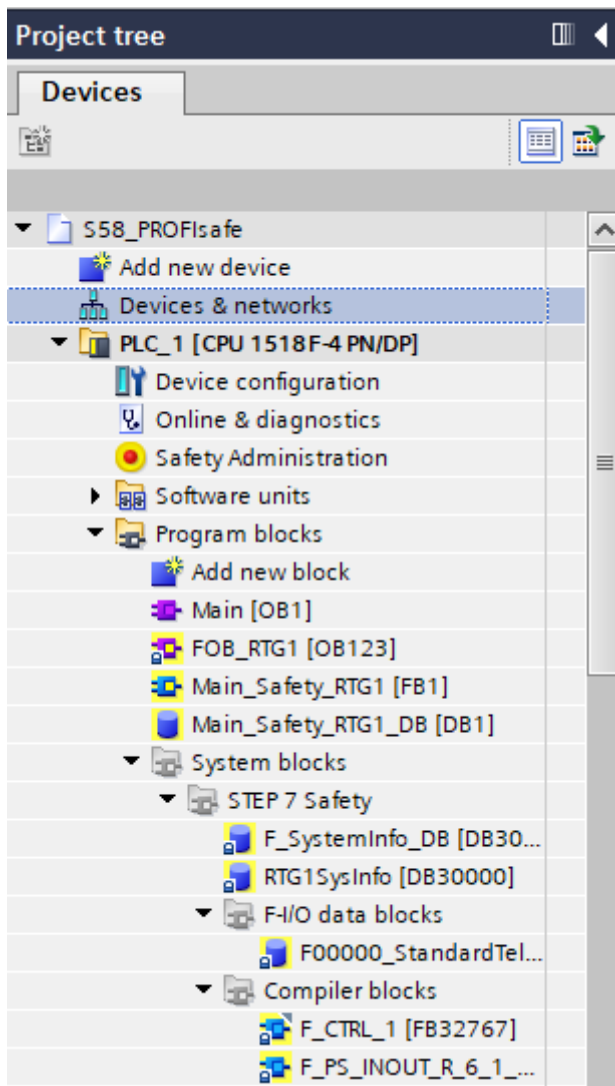

IMG-ID: 236786955

- f) Click on “Add new block” to create a new block.
⇒ A window offering several options opens.

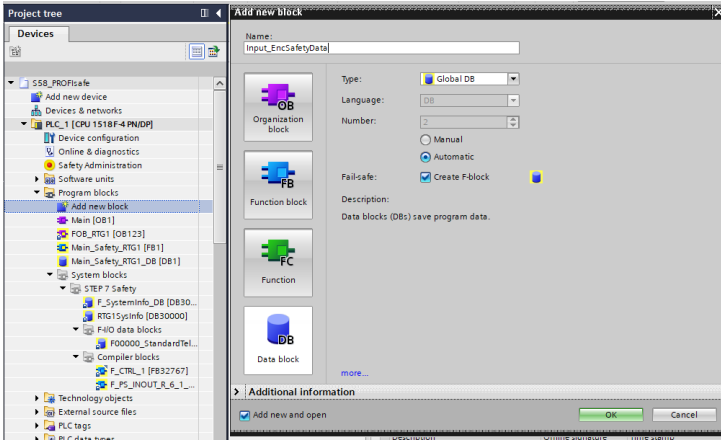

IMG-ID: 236794635

- g) Set the type on "Global-DB" and assign a suitable name such as e.g. Input_EncSafetyData.
- h) Check the box for the option "Create F-block".
- ⇒ The block is now added to the project.

Creating variables for process input and output data

First, the process input variables are created in the safe data block.

- a) Navigate in the project tree to the safe data block. In this example, "Input_EncSafetyData".
- b) Create a variable for each of the input data. These are in this example: velocity, position and the encoder status word. The data type is DIInt.
- ⇒ The safe data block is now prepared for the process input data.

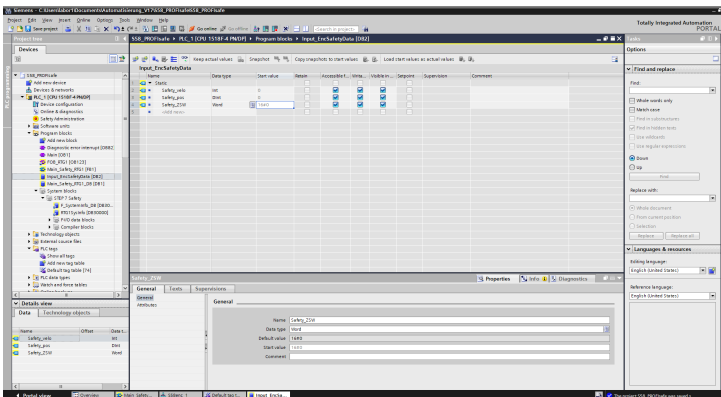

IMG-ID: 236804235

Name	Address	Display for...	Monitor value	Modify value	Comment	Tag c...
// Position value						
"q1_HST1"	%Q24	DEC				
"q1_VELO"	%Q28	DEC				
// Speed value TeB2						
"HST_A"	%W32	DEC				
// Control Data Encoder						
"s2W2_ENC"	%QW0	Bin		240000_0100_0000_0000	Bit10 = 1 Control by PLC	
"q1_SWP"	%QW2	Bin		240000_0000_0000_0000	Bit1 = 0 Parking Sensor Off, Bit12 = Preset.	
"tag_S_Preset_Enabled"	%AO.1	Bool		FALSE		
"tag_S_Preset_Activate"	%AO.2	Bool		FALSE		
// Status Data Encoder						
"s2W2_ENC"	%QW0	Bin				
"q1_SWP"	%QW2	Bin				
// Safety Data Encoder						
"s2W2_ENC"	%AO.0	Bool		FALSE		
"s2SWL_ENC"	%AO	Hex				
"s2_HST1_VELO"	%W2	DEC				
"s2_HST1_Pos"	%W4	DEC				
"s2W2_ENC"	%QW0	Hex			Bit0 = 1 Preset activated, Bit6 = trigger Bit Reset	
-Add new-						

IMG-ID: 249766155

Storing the program blocks

In order to be able to process the input and output data of the safe encoders, the required variables, runtime groups and blocks must be stored in the controller. This takes place using the standard safety elements of the controller.

The safety program of the controller has highest priority, both in terms of time and content. This means that, prior to any program run of the standard user program, the safety program is processed first. This is achieved by means of block "FOB_RTG1 (OB123)". This block calls cyclically the main safety routine "Main_Safety_RTG1 (FB1)". The corresponding data is managed in data block "Main-Safety_RTG1_DB (DB1)".

Blocks must now be added to handle interruptions that might occur during operation.

Without these blocks, e.g. a preset would lead to an error. These blocks also allow carrying out initial operations even before performing the main safety routine.

- a) Select the integrated controller in the project tree and click on "Add new block".

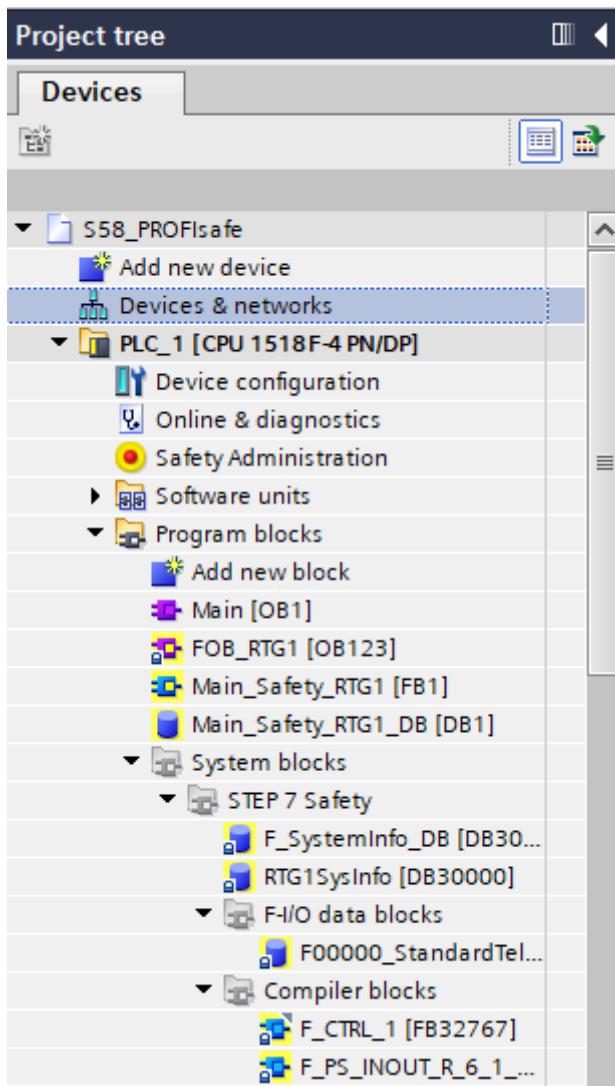

IMG-ID: 236786955

- b) In the window that opens, select the following blocks one after another: Organization block OB82 - Diagnostic error interrupt, OB83 - Pull or plug of modules, OB86 - Rack or station failure and OB122 - IO access error.
- ⇒ The blocks are added to the project.

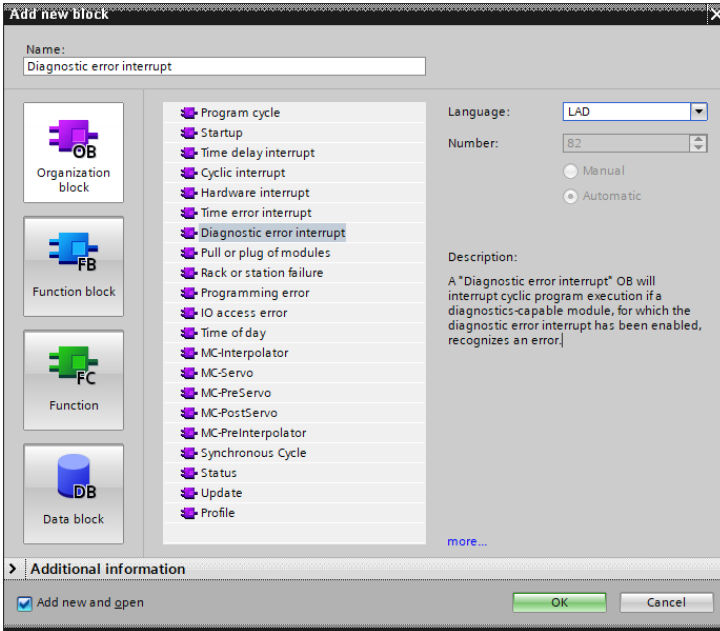

IMG-ID: 236796555

Now, the required instructions, which are necessary for depassivation and process data storage, are stored in the safety main routine.

c) Select the safety main routine “Main_Safety_RTG1”.

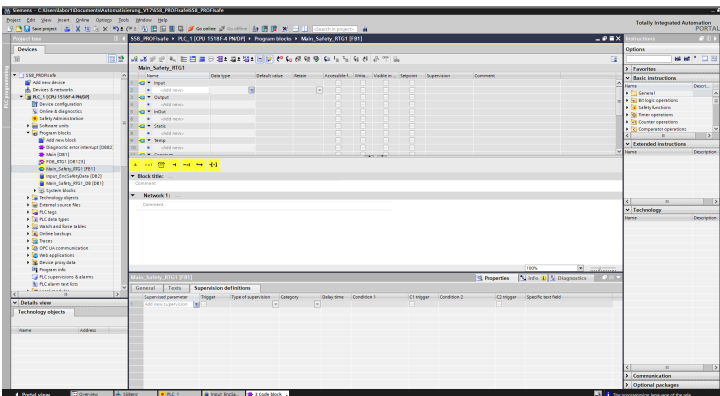

IMG-ID: 236798475

d) Store here every time a “&” and a “=” instruction, as represented below. Link them with the “user_ack” and “F00000_StandardTelegram36(BP)”.ACK_REI“ tags.

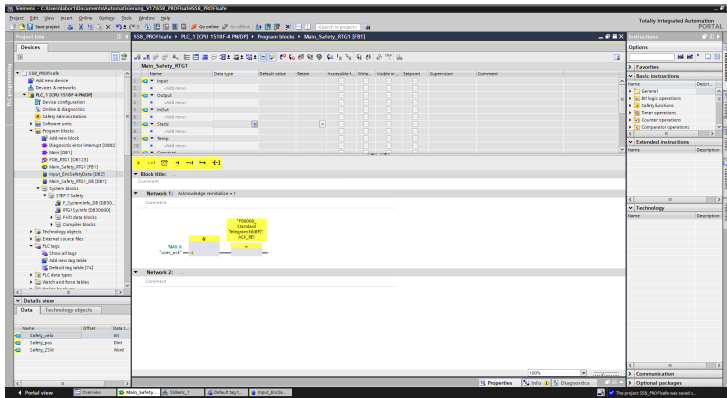

IMG-ID: 236806155

e) Also link the variables "S_NIST16_Velo" and „S_XIST32_Pos“ with the respective tags of the safe data block by means of a "MOVE" command.

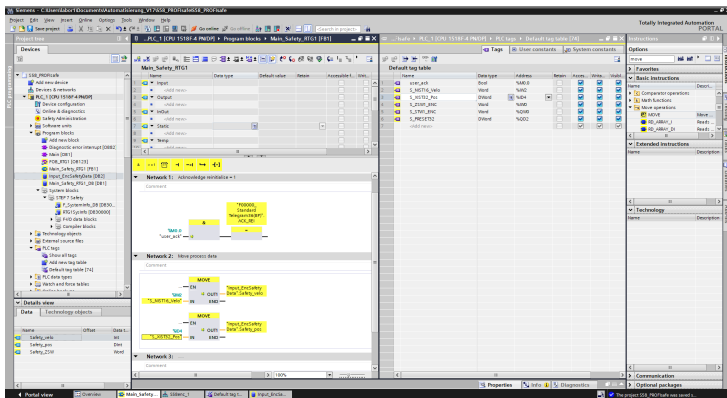

IMG-ID: 236808075

f) Now add the commands for preset handling. To do so, create two MOVE commands "Tag_S_Preset_enable" and "Tag_S_Preset_activate" for the respective bits in S_STW1_ENC" an.

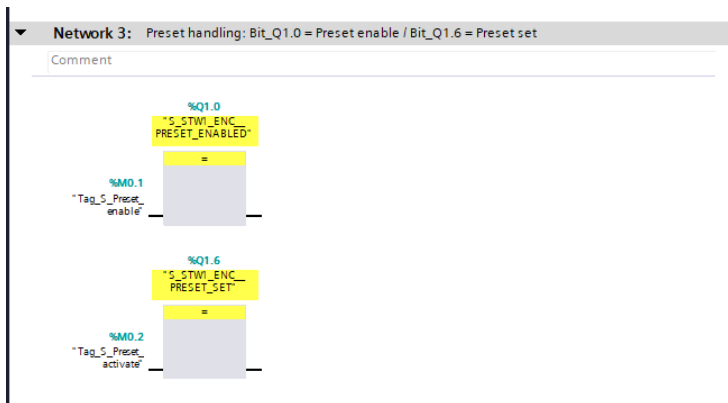

IMG-ID: 250359051

5.2.2 Tool Calling Interface - TCI

Since the S58 PROFIsafe is a functional safety device, the safety standard requires the exclusion of faulty configuration during configuration.

NOTICE	Need of the CRC calculation with TCI
	In case of a safety-oriented configuration, it must be made sure that a proper configuration, i.e. a configuration checked by the user, is sent to and saved in the target device. This is achieved by a comparison of the CRC value calculation in TIA Portal and of the CRC value calculation in the device itself.

TIA Portal provides innately various polynomial approaches, as well as the possibility to integrate own user-specific safety mechanisms.

The “Kübler TIA Device Tool” takes in charge the CRC calculation of the configuration to be loaded through TIA Portal in the S58 PROFIsafe encoder. The tool is started from TIA-Portal using the TCI.

The CRC is calculated for the module parameters (iParameters). It checks whether the suitable parameters for the device have been transmitted and makes sure that no transmission errors occurred.

5.2.2.1 Installation

The Kübler TIA Device Tool can be operated on Windows operating systems. Proceed as follows for the installation.

- ✓ The Kübler TIA Device Tool can be [downloaded from the Kübler Website](#).
- a) Run the file “Kuebler TCI Device Tool.exe”
 - ⇒ The window below opens:

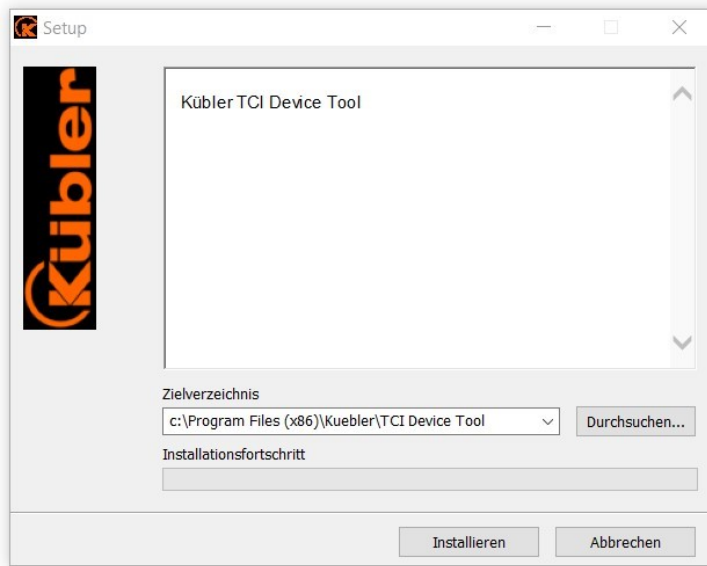

IMG-ID: 247573003

- b) Define the target directory. The target directory can be the default directory or any other directory selected by the user.
- ⇒ After the directory selection, a windows query relating to user account control is displayed.
- c) Confirm the query.
- ⇒ Now the required changes can be made at the Windows device.

NOTICE	Confirmation of the changes
	The confirmation of the changes in the user account control will be required for the future use of the Kübler TIA Device Tool.

These confirmed changes include entries in the registration of the Windows device.

The need for the changes in the entries is based on the fact that TIA Portal then contains the path to the program (Kübler TIA Device Tool) and therefore can assign the program to the corresponding device to be configured.

In addition, entries are made that will allow an error-free uninstallation of the Kübler TIA Device Tool.

5.2.2.2 CRC value calculation

Once all presets for the configuration have been completed, the CRC value can be calculated. The CRC value of the configuration data is calculated manually by the operator.

- ✓ Make sure that the device has been created in TIA Portal and that the GSD file has been loaded.
 - ✓ Make sure that the module parameters / iParameters (e.g. resolution) have been set.
- a) Open the device configuration for the device in TIA Portal in order to start the CRC calculation.
- b) Right click on the device, i.e. on the representation.
- ⇒ A menu window for the processing of the encoder settings and configuration opens.

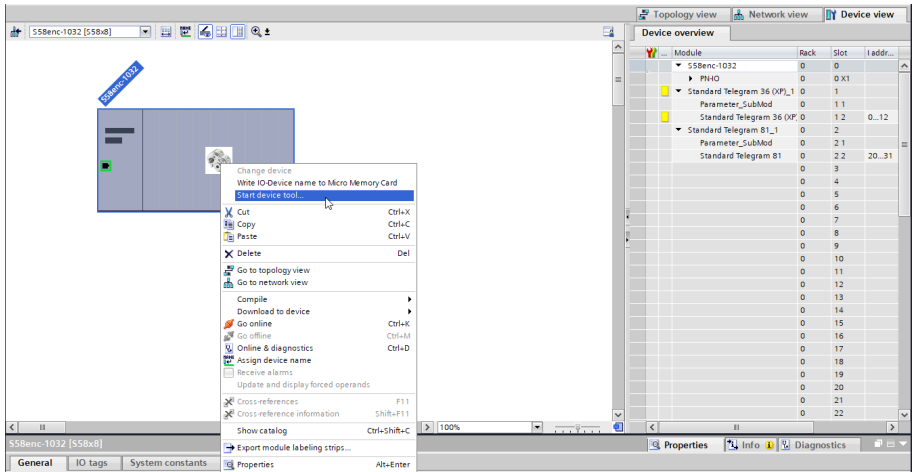

IMG-ID: 9007199508210187

- c) Select menu item “Start Device Tool ...” and press the “Start” button.
- ⇒ Starting the Kübler TIA device tool opens a new window.

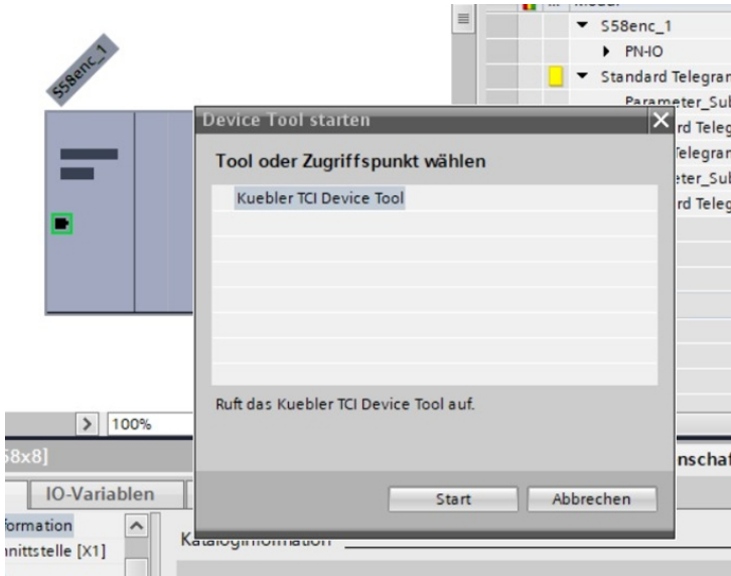

IMG-ID: 233440011

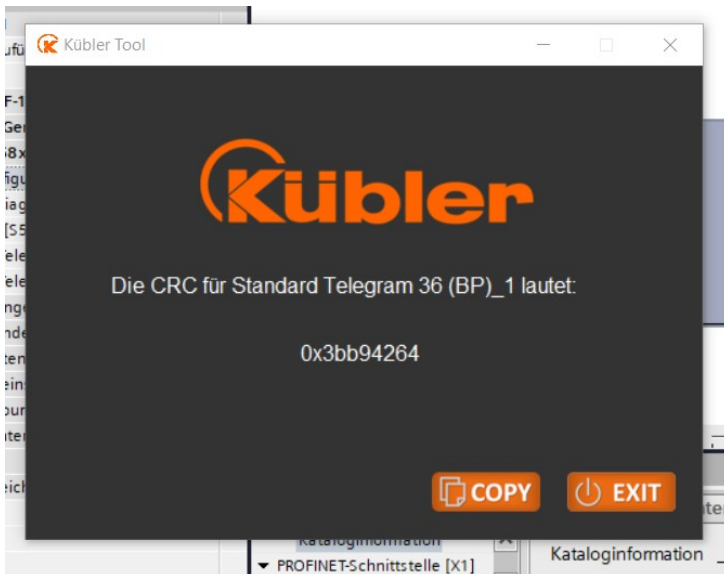

IMG-ID: 233442443

d) Confirm with the “Copy” button.

- ⇒ The CRC calculation is performed automatically for the linked encoder when starting the Kübler TIA device tool.
- ⇒ The CRC calculation is performed for the whole safety-relevant configuration (encoder settings).

⇒ The generated CRC value is stored in the buffer memory for further processing. Click in TIA Portal to call the “Device configuration” back to the foreground:

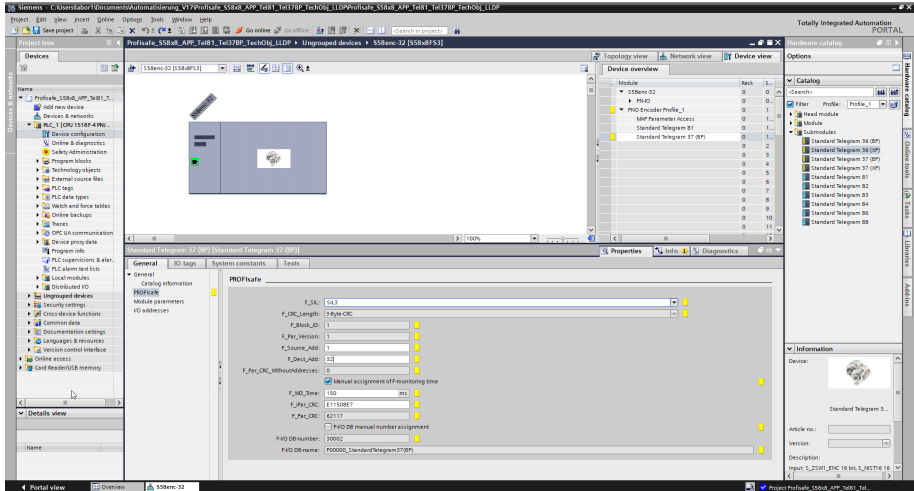

IMG-ID: 9007199539005451

NOTICE	<p>Buffer memory</p> <p>The buffer memory is erased when closing the program.</p>
---------------	--

- e) Select the required telegram in the Kübler TIA device tool. In this example, standard telegram 36 (BP)_1 is selected.
- f) Input the previously generated and copied CNC value in TIA Portal under F_IPar_CRC. The input mask for the CRC values of the F-parameterizing can be found in submenu item “PROFIsafe” of the selected telegram.
- g) After selecting the input field F_IPar_CRC, input the CRC value stored in the buffer memory with a right click or Ctrl+V
 - ⇒ The safety-relevant configuration is then secured by the CRC value.

NOTICE	<p>Further change of the configuration</p> <p>If values are changed in the configuration after the calculation of the CRC value, the tool must be started again to calculate the new value.</p>
---------------	--

5.2.3 Commissioning

NOTICE	<p>Identifying the IP address</p> <p>The IP address of the device can be found with "Project tree/Online accesses/Network board/Update accessible nodes".</p>
---------------	--

NOTICE	<p>Parking sensor is active in the initial state</p> <p>For the standard telegrams 81, 82, 83 and 84 according to Encoder Profile v4.2, the parking sensor is active in the initial state, in which the encoder does not output data or the position is frozen. To set the encoder in the operating state, the parking sensor can be deactivated with bit 14 in G1_STW.</p>
NOTICE	<p>Sensors passivated in initial state</p> <p>In the initial state, the safety-oriented sensor is passivated in a first phase due to the safety mechanisms. This means that the sensor will not accept commands until it has been depassivated by means of the ACK_REI bit.</p>

- ✓ Make sure that all required configuration parameters have been set properly.
- ✓ Make sure that the CPU IP address set in the device configuration corresponds to the actual IP address.
 - a) Click on your CPU (e.g. under "Project tree/Devices" and then on symbol "Load in device".
 - ⇒ The window "Load preview" opens.
 - b) Click on "Load" and subsequently on "Finish".
 - ⇒ This loads the hardware configuration in the PLC.

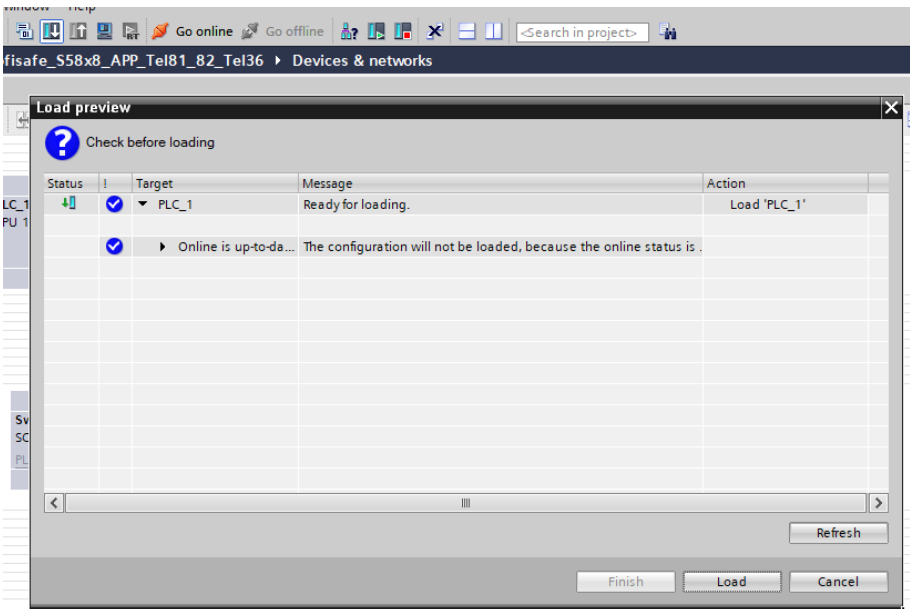

The configuration can then be started.

- c) To do so, click on "Go online".
- ⇒ The encoder is now online.

Generation of the Ready for operation state

NOTICE	Conditions for process data transmission
	Before process data communication can take place, the safe operating state must be acknowledged by the user. This occurs via the depassivation for the safe channel or via the cancellation of the parking sensor for the non-safe channel (Tel 81, 82, 83, 84).

Name	Address	Display for...	Monitor value	Modify value	Comment	Tag c...
1 Position value						
2 "G1_MST1"	%M24	DEC	582351			
3 "G1_MST2"	%M28	DEC	0			
4 Speed value Tel82						
5 "NST_A"	%M02	DEC+/-	0			
6 Control Data Encoder						
8 "STW2_ENC"	%M020	Bin	240000_0100_0000_0000	240000_0100_0000_0000	<input checked="" type="checkbox"/> Bit0 = 1 Control by PLC	
9 "G1_STW"	%M021	Bin	240000_0000_0000_0000	240000_0000_0000_0000	<input type="checkbox"/> Bit4 = 0 Parking Sensor OK, Bit12 = Preset.	
10 "Tag_S_Preset_Activate"	%M0.1	Bool	<input type="checkbox"/> FALSE	FALSE		
11 "Tag_S_Preset_Activate"	%M0.2	Bool	<input type="checkbox"/> FALSE	FALSE		
12 Status Data Encoder						
13 "ZSW2_ENC"	%M020	Bin	240000_0010_0000_0110			
14 "G1_ZSW"	%M022	Bin	240000_0000_0000_0000			
15 (Safe) Data Encoder						
16 "user_ack"	%M0.0	Bool	<input type="checkbox"/> FALSE	FALSE		
17 "S_ZSW2_ENC"	%M0	Hex	1640003			
18 "S_MST12_Inv"	%M02	DEC+/-	0			
19 "S_MST12_Pos"	%M04	DEC	5045			
20 "STW2_ENC"	%M020	Hex	1640400		Bit0 = 1 Preset activated, Bit6 = trigger Bit Reset	
21	...					

IMG-ID: 249772171

Proceed respectively as follows to generate the Ready for operation state.

Safe channel:

- ✓ The parking sensor must be deactivated in order to allow the output of measured values via telegrams 36 and 37.
- a) Click on button "Download on the device" to load the configuration in the controller. Then confirm with "Load".
- b) Switch with the controller to the RUN mode.
- c) Now set variable "user_ack" to 1 (TRUE) and send the command via the controller.
 - ⇒ The routine depassivates the encoder.
- ⇒ After having depassivated the encoder, the current measured values of the encoder are displayed.

Non-safe channel (Tel 81, 82, 83, 84):

- ✓ The parking sensor must be deactivated in order to allow the output of measured values.
- d) Click on button "Download on the device" to load the configuration in the controller. Then confirm with "Load".
- e) Switch with the controller to the RUN mode.

- f) To monitor the input and output data, open the created monitoring table and click on "Monitor all".
 - g) Deactivate the parking sensor by setting in STW2_ENC bit 10=1 and in G1_STW bit 14=0. Telegram data
- ⇒ As soon as the configuration is started and the parking sensor deactivated, the values output by the encoder can be read.

5.2.4 Resetting to Factory Settings

The PROFINET interface of the encoder can be reset to the "factory settings". This erases among others the device name and the IP address.

NOTICE	Preset position
	"Resetting to factory settings" only relates to the PN interface. The preset position of the encoder is not affected.
NOTICE	Output data behavior
	<p>The output data bytes processed internally by the encoder are set to 0x00 and therefore erased in the following situations:</p> <ul style="list-style-type: none"> • when powering (applying the supply voltage). • at every PN link interruption (e.g. disconnecting the PN data line). • when the PN controller sets "IOPS=BAD"(e.g. when the PLC switches to "STOP").
NOTICE	Device name
	If the PN controller (PLC) is currently in operation and contains a LLDP configuration corresponding to the current topology, the configured name is automatically assigned to the device just reset to "factory settings" (and if necessary the PN link is set up again) after some seconds.

If a defective device is to be replaced in a PROFINET network, it is recommended to mount a new replacement device or a device reset to factory settings. It will then automatically be assigned the correct PROFINET device name if LLDP is enabled - see LLDP - Link Layer Discovery Protocol.

Proceed as follows to "reset to factory settings":

- a) Open path "Project tree/Devices/Online access/{Your PN network card}".

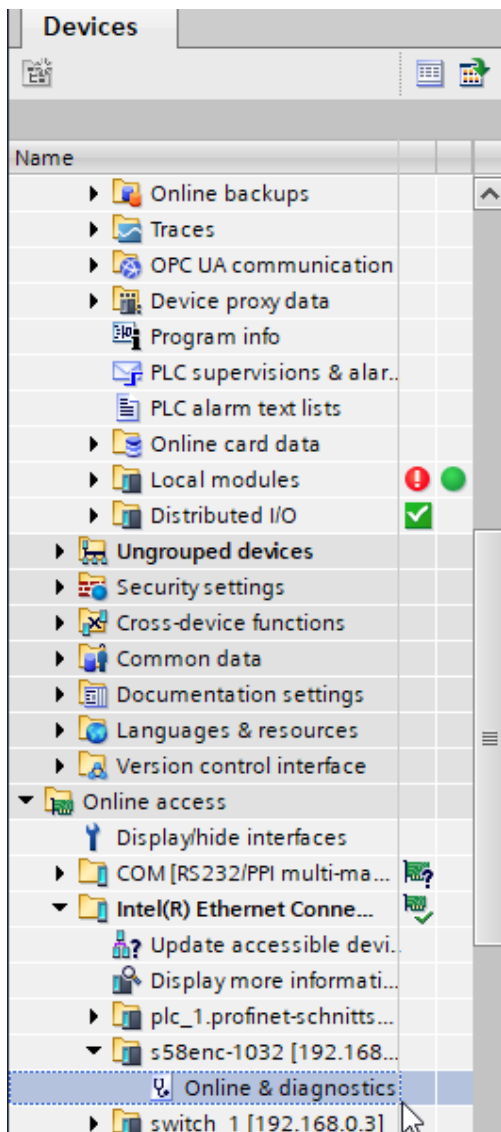
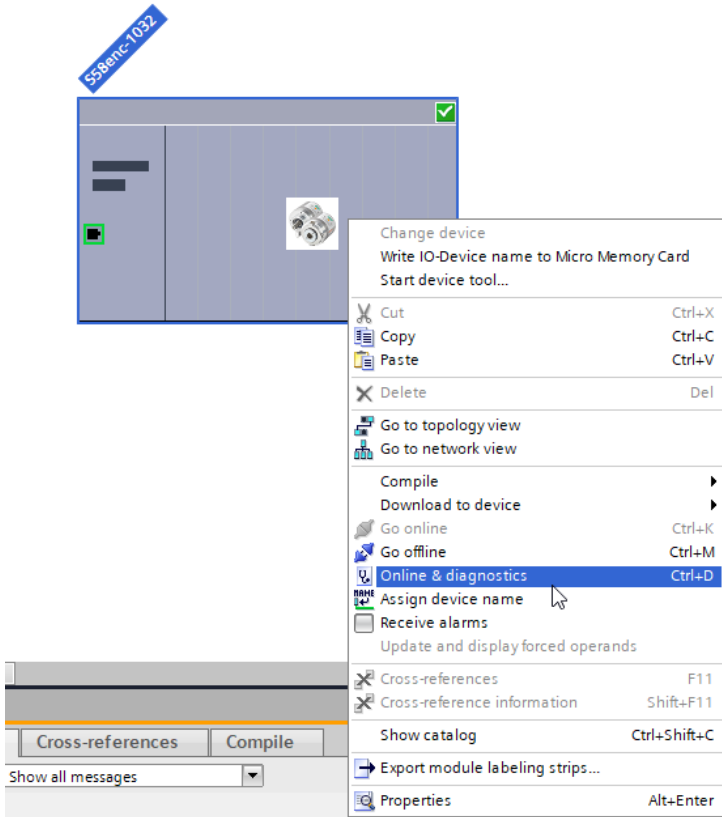

Fig. 1:

IMG-ID: 249725195

- b) Double-click on "Update accessible devices"
- c) Wait some seconds until the search process is completed and the list of the accessible PN devices is displayed.
- d) Double-click on "Online & Diagnostics" of the encoder to be reset. Alternatively you can also make directly a right click on the encoder in the topology view and select there the menu item.



IMG-ID: 249728779

e) Select "Functions/Reset to factory settings".

f) Click on "Reset".

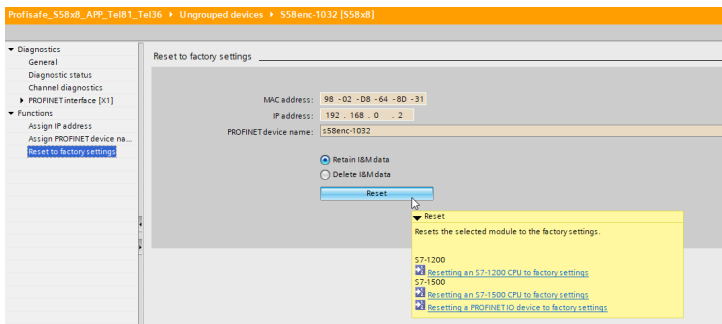

IMG-ID: 249743243

g) Select whether also the I&M data is to be reset.

⇒ A warning message is displayed.

- h) Confirm the warning message with "Yes".
 ⇒ The encoder is now reset to the factory settings.

NOTICE	Effect of the reset to the factory settings
	As soon as the device is reset to the factory settings, the supply voltage must be switched off and on again. The device is then ready for use again, but in passivated status. For process data communication, it must first be depassivated. Commissioning [► 50]

5.3 Protocol Features

5.3.1 PROFINET

5.3.1.1 Encoder Model

PROFINET is represented on the encoder in accordance with the encoder model described in Encoder Profile V4.2. The main component of this model is the PROCESS CONTROL TASK. It ensures that the measured values are acquired and transmitted. The acquired and calculated values are also controlled by the configuration parameters.

Data communication can be subdivided into 4 main areas, which are all supported by the encoder.

- ALARM QUEUE: Output of warnings and alarms.
- CYCLIC DATA EXCHANGE (RT).
- ACYCLIC DATA EXCHANGE (configuration parameters)
- CLOCK SYNCHRONOUS OPERATION: synchronous data exchange (IRT).

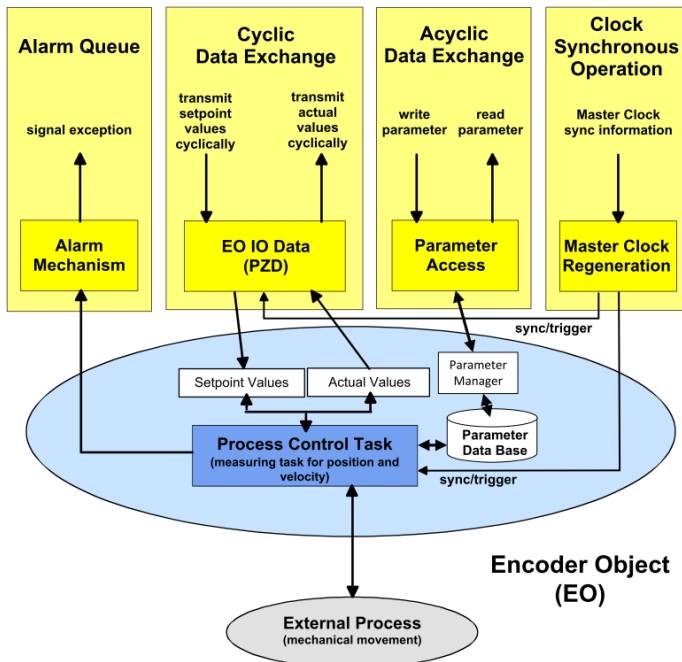

IMG-ID: 177715851

5.3.2 PROFIdrive

5.3.2.1 PROFIdrive Base Model

PROFIdrive describes the basic structure in which the PROFINET encoder model integrates itself. Every P device (PROFINET device, in the specific case the encoder) consists of an APPLICATION LAYER and a COMMUNICATION LAYER.

The DRIVE OBJECT can be subdivided in various communication services:

- ALARM MECHANISM: Output of alarms and warnings
- CYCLIC DATA EXCHANGE (RT)
- ACYCLIC DATA EXCHANGE (configuration parameters)
- CLOCK SYNCHRONOUS OPERATION: synchronous data exchange (IRT)

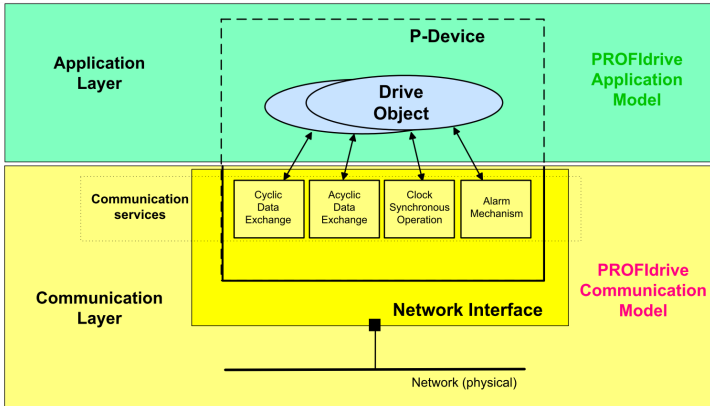

IMG-ID: 179289995

The DRIVE OBJECT communication predefined this way determines the base according to which the Encoder Model is oriented.

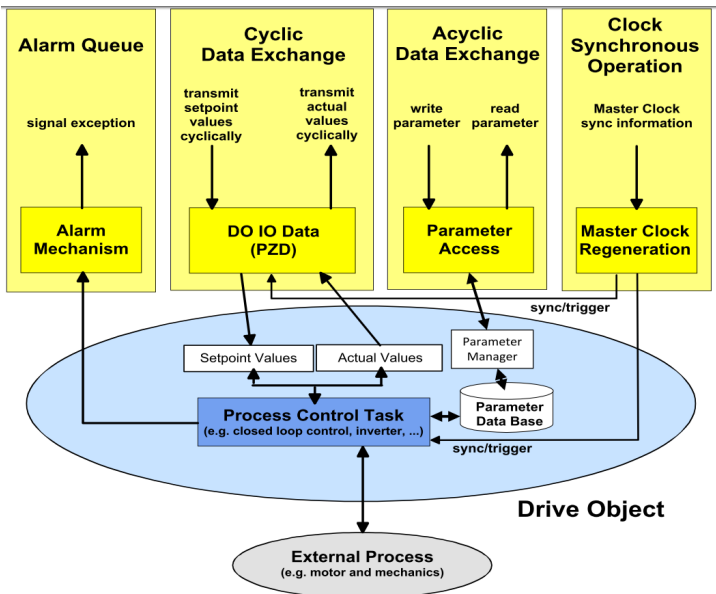

IMG-ID: 179293835

PROFIdrive in particular describes the way to ensure clock synchronous process data, which is of crucial importance in closed drive system control loops. It allows achieving, for clock synchronous process data transmission, cycle times of less than 1 ms: the control issues a transmit clock cycle used by all PROFIdrive network participants for synchronization.

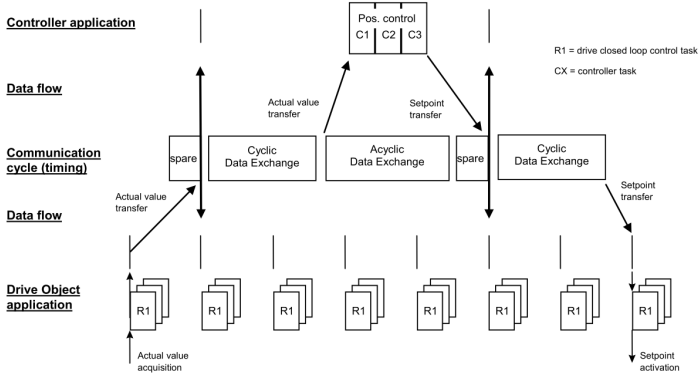

IMG-ID: 179333899

A part of the cyclic communication is reserved for the acyclic communication. It is generally used only if required. It includes e. g. status information of network participants or commands, as well as parameterizing data.

The PROFIdrive profile operates in accordance with the so-called client-server model, in which the communication generally takes place via request and response. Special PLC blocks are available for this purpose, allowing addressing such commands to the network participant.

5.3.3 PROFIsafe

PROFIsafe is based on the existing data models of PROFINET and PROFIdrive and extends the additional safety-oriented mechanisms with the data transfer, but also the data content.

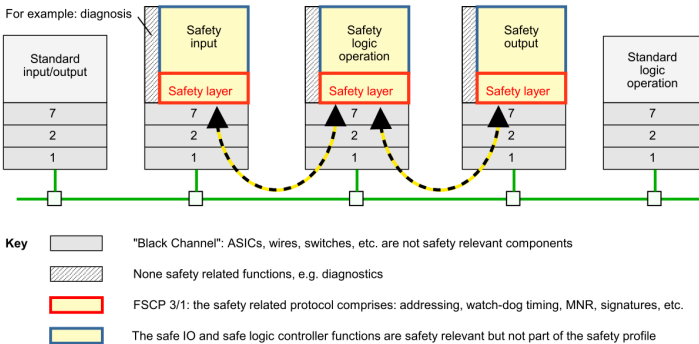

Figure 7 – Safety layer architecture

IMG-ID: 246423179

These are essentially the mechanisms such as e.g. the exclusion of data manipulation, data loss or data delay.

Communication error	Safety measures			
	(virtual) MonitoringNumber ^a	Timeout with receipt ^b	Codename for sender and receiver ^c	Data integrity check ^d
Corruption	–	–	–	X
Unintended repetition	–	X	–	–
Incorrect sequence	X	–	–	–
Loss	X	X	–	–
Unacceptable delay	–	X	–	–
Insertion	X	–	–	–
Masquerade	–	–	–	X
Addressing	X	–	X	–
Out-of-sequence	X	–	–	–
Loop-back of messages	x ^e	–	–	–

^a Instance of "sequence number" of IEC 61784-3.
^b Instance of "time expectation" (Timeout) and "feedback message" (Receipt) of IEC 61784-3.
^c Instance of "connection authentication" of IEC 61784-3.
^d Instance of "data integrity assurance" of IEC 61784-3, based on CRC signature.
^e in mode F_CRC_Seed =0 via status bit 7, in mode F_CRC_Seed =1 via one's complement of MNR

IMG-ID: 246419595

The PROFIsafe communication always provides a safety-oriented (safe) channel and a non safety-oriented (non-safe) channel. Both channels can be used simultaneously if this possibility is available in the terminal device. Multi-master systems can also be set up, which may be either several F-hosts or a single F-host and further non-safe hosts. However, "Shared F-inputs" are not allowed.

While both PROFINET and PROFIdrive allow adapting and taking over parameters directly, for PROFIsafe, it must always be made sure that no undefined states can occur. This is prevented by a passivation of the F-device that must be acknowledged by the user. Undefined or wrong configurations of the F-device are prevented as well by having a checksum generated by a program outside the projecting tool that must be confirmed by the new configuration.

5.4 Configuration Parameters Description

5.4.1 Base Mode Parameter

The following picture shows the encoder parameters database linked with the encoder application process and its associated mechanisms for the access to and the initialization of the parameter data. Also the optional mechanisms are implemented.

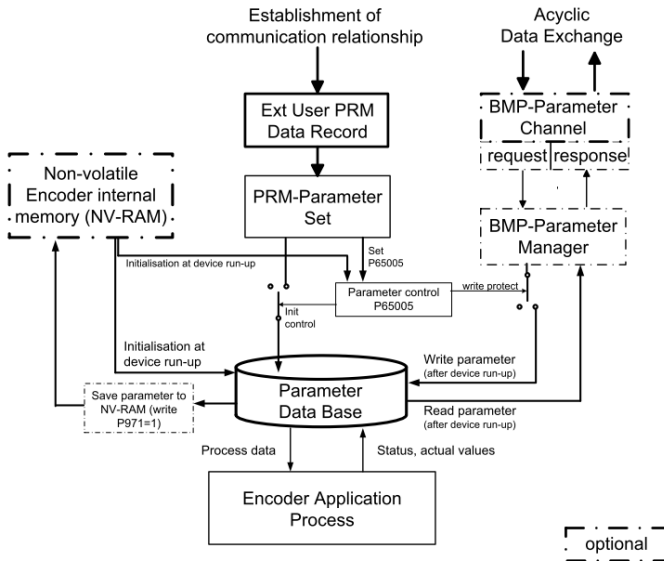

IMG-ID: 284210571

The use of the BMP parameters channel allows reading all implemented parameters. The write access to parameters through the BMP parameters channel is based on the setting of parameter "Parameter control" P65 005.

The initialization of the parameters data base during encoder start-up depends on the setting of parameter "Parameter control" in the PRM parameters set.

During encoder start-up (switching on), the content of the parameters data base is loaded from the NV-RAM of the encoder.

When establishing a communication relation with a parameterizing controller, the controller transmits the User Parameter Data Block (PRM data block) to the device. According to the setting of parameter "Parameter control" P65 005, the PRM data block is rejected or initialized. The parameters in the parameters data base correspond to the content of the PRM data block.

To save parameters in the NV-RAM, the parameters are in a first phase set in the parameters data base (via BMP parameters channel or PRM data block), and then the parameters are saved via. p971=1 (BMP parameters).

NOTICE	Saving the configuration
	<p>It is strongly recommended to save the new permanent configuration in the NV-RAM (P971=1), as the position may deviate after a restart.</p> <p>Determined runtime parameters are always saved in the NV-RAM for every configuration, and they are reset in the event of a new configuration. If a set configuration is not saved, it will deviate from the current configuration in the NV-RAM. After a restart, the encoder loads the configuration from the NV-RAM and the runtime parameters are reset. This may lead to position deviations.</p>

Access to the encoder parameters takes place through submodule "MAP Parameter Access" with "Record Data Object 0xB02E", in compliance with Encoder Profile V4.2.

The base mode parameters, for which "Effective" is marked with "Reset", are written in the parameters data base while parameterizing, but they are not saved in the device.

Only parameter "Transfer to non volatile memory" (P971=1) will write the data in the non-volatile memory to allow taking them over upon an encoder reset.

Write Access

- "Write request" by the IO controller with parameter number and the user data to be written.

Slot			BYTE	0x01
Subslot			BYTE	0x01
Index			WORD	0xB02E
Data Length			BYTE	individual
Data	Request Header	Request Reference	BYTE	
		Request ID	BYTE	0x01 = "Read" / 0x02 = "Write"
		Drive Object ID	BYTE	0x00
		Number of Parameters	BYTE	0x01
	Parameter Address	Attribute	BYTE	
		No. of Elements/ Values	BYTE	
		Parameter Number	WORD	
		Subindex	WORD	
	Parameter Value	Format / Data Type	BYTE	for "Write request"
		Number of values	BYTE	for "Write request"
		Values to write (if any)	BYTE	for "Write request"

- A "Write response" from the IO device.

Slot	BYTE	0x01
Subslot	BYTE	0x01
Index	WORD	0xB02E
Data Length	BYTE	individual

Read access

- "Write request" by the IO controller. Transmits which parameters are to be read.
- "Write response" from the IO device
- "Read request" from the IO controller

Slot	BYTE	always 0x01
Subslot	BYTE	always 0x01
Index	WORD	always 0xB02E
Data Length	BYTE	as from here (excl.)

- "Read response" from the IO device with the requested user data.

Slot			BYTE
Subslot			BYTE
Index			WORD
Data Length			BYTE
Data	Response Header	Response Reference	BYTE
		Response ID	BYTE
		Drive Object ID	BYTE
		Number of Parameters	BYTE
	Parameter Value	Format / Data Type	BYTE
		Number of values	BYTE
		Values	see format

5.4.1.1 PROFIdrive Parameters

Parameter number	Meaning	Data type	Permissi on	Effective
922	Telegram selection	UINT8	R	
925	Number of Controller Sign-Of-Life failures which may be tolerated	UINT8	R/W	Immediately
964	Drive unit identification	Array UINT16	R	-
965	Profile identification number	Array Octet string 2	R	-
971	Transfer to non volatile memory	UINT16	R/W	Immediately
972	Reset Encoder device	UINT16	R/W	Immediately
974	Base Mode Parameter Access service identification	UINT8	R	
975	DO identification	Byte Array [16]	R	
979	Sensor format	UINT32	R	
980	Number list of defined parameter	Array UINT16	R	

Parameter 922: Telegram selection

This parameter allows reading the parameterized telegram type.

Parameter value	Telegram
81	PROFIdrive telegram 81
82	PROFIdrive telegram 82
83	PROFIdrive telegram 83
84	PROFIdrive telegram 84
86	Telegram 86 with 32 bits for position + 32 bits for velocity
88	Telegram 88 with 64 bits for position + 32 bits for velocity

Parameter 925: Number of controller sign-of-life failures which may be tolerated

This parameter reads or writes the number of errors of the controller "sign-of-life" to be tolerated.

Valid values range: 1 ... 255

NOTICE	
	Writing the parameter is only possible when the Master lifesign is disabled.

Parameter 964: Drive unit identification

This parameter allows reading a data set for encoder identification.

Parameter	Meaning
964[0]	Manufacturer ID
964[1]	Drive Unit Type (manufacturer-specific)
964[2]	Firmware version e. g. 0x0064 = 100 corresponds to V1.00
964[3]	Firmware year e. g. 0x07E4 = 2020
964[4]	Firmware day and month e. g. 0x0067 = 103 corresponds to 1.03
964[5]	Number of Drive Objects

Parameter 965: Profile identification number

This parameter reads the PROFILE ID of the encoder profile and its parameterized version.

Parameter	Meaning
965[0]	Profile ID: 0x3D abbreviated
965[1]	0x1F = 31 = V3.1 0x2A = 42 = V4.2

Parameter 971: Transfer to non-volatile memory

This parameter allows storing the current parameters set (configuration) in the non-volatile memory.

Parameter value	Meaning
0	Default, no effect
1	Storing the current parameters set in the non-volatile memory

Parameter 972: Reset Encoder device

This parameter allows restarting the non-safe application.

Parameter value	Meaning
0	Default, no effect
1	Restart of the non-safe application

Parameter 974: Base mode parameter access service identification

This parameter reads three features of the parameter channel:

- Max. data length
- Multi-parameter access ability.
- Max. processing time for an access as an indication for a customer-side timeout.

Parameter	Meaning
974[0]	Max. data length (240 bytes = 0x00F0)
974[1]	Max. number of parameter requests per multi-parameter request
974[2]	Max. access processing time

Parameter 975: DO identification

This parameter reads the following information in the encoder:

Parameter	Meaning
975[0]	Manufacturer ID
975[1]	Drive Unit type (manufacturer-specific - F58 = 0x2190)
975[2]	Firmware version e. g. 0x0064 = 100 corresponds to V1.00
975[3]	Firmware year e. g. 0x07E4 = 2020
975[4]	Firmware day and month e. g. 0x0067 = 103 corresponds to 1.03
975[5]	PROFIdrive Type Class
975[6]	PROFIdrive DO Subclass 1
975[7]	Drive Object ID

Parameter 979: Sensor format

This parameter reads the set user parameters of the encoder.

Parameter	Meaning
979[0]	Header Info
979[1]	1st Sensor (G1) Type (**)
979[2]	Sensor Resolution
979[3]	Shift Factor for G1_XIST1
979[4]	Shift factor for absolute value in G1_XIST2
979[5]	Determinable Revolutions
979[6]	reserved
979[7]	reserved
979[8]	reserved
979[9]	reserved
979[10]	reserved

Parameter 980: Number list of defined parameter

This parameter reads all supported parameter numbers.

Parameter	Meaning
980[0]	922
980[1]	925
980[2]	964
980[3]	965
980[4]	971
980[5]	972
980[6]	974
980[7]	975
980[8]	979
980[9]	1002
980[10]	1003
980[11]	60000
980[12]	60001
980[13]	60022
980[14]	60023
980[15]	60024
980[16]	60025
980[17]	65000
980[18]	65001
980[19]	65002
980[20]	65004
980[21]	65005
980[22]	65006
980[23]	65007
980[24]	65008
980[25]	65009
980[26]	65100
980[27]	0 = End Mark

5.4.1.2 Encoder Parameters

The encoder features the following setting options/parameters:

Parameter number	Meaning	Data type	Effective	Permission
1002	Upload Counter	UINT32	-	R
1003	F_Dest_Add	UINT16	-	R
60000	N2/N4 velocity reference value	Float32	Reset	R/W
60001	Velocity value normalization	UINT16	Reset	R/W
60 022	Safety Telegram Number	UINT16	-	R
60023	Safe Speed Value Normalisation	UINT16	-	R
60024	Safety Setpoint Telegram	Array[n] UINT8	-	R
60025	Safety Actual Value Telegram	Array[n] UINT8	-	R
65000	Preset value	INT32	Immediately	R/W
65001	Operating status	Array[n] UINT32	-	R
65002	Preset value 64 bits	INT64	Immediately	R/W
65003	Reserved			
65004	Function control	UINT32	Reset	R/W
65005	Parameter control	UINT16	Reset	R/W
65006	Measuring units per revolution (MUR)	UINT32	Reset	R/W
65007	Total measuring range in measuring units (TMR)	UINT32	Reset	R/W
65008	Measuring units per revolution (MUR) 64 bit	UINT64	Reset	R/W
65009	Total measuring range in measuring units (TMR) 64 bit	UINT64	Reset	R/W
65100	Operating status	Array[n] UINT32	-	R

Parameter 1002: Upload Counter

Is incremented at every configuration. Read-only parameter.

Parameter 1003: F_Dest_Addr

Returns the biunique F_Dest_Addr set. Only for request.

Parameter 60000: N2/N4 velocity reference value

The velocity reference value returns the 100% value of the N2/N4 ratio and is to be understood as a percentage. N2/N4 thus indicates the ratio of NIST to NSOLL. It is always displayed with relation to the values NIST_A and NIST_B. NIST_A is the velocity in 16 bits length, NIST_B is the velocity in 32 bits.

Parameter 60001: Velocity value normalization

This parameter defines the unit of the actual velocity values. The unit relates to the values NIST_A and NIST_B

Velocity unit	Value
Steps/s	0
Steps/100ms	1
Steps/10ms	2
RPM	3
N2/N4 normalized	4

Parameter 60 022: Telegram selection

This parameter allows reading the parameterized telegram type for Safety.

Parameter value	Telegram
36	PROFIdrive telegram 36 (BP)
65572	PROFIdrive telegram 36 (XP)
37	PROFIdrive telegram 37 (BP)
65573	PROFIdrive telegram 37 (XP)

Parameter 60 023: Safe Speed Value Normalisation

This parameter returns the unit configured for the safe velocity values currently transmitted in signal S_NIST16.

Parameter 60 024: Safety Setpoint Telegram

Represents the content of the safety telegram received in the last PROFIsafe cycle.

Parameter 60 025: Safety Actual Value Telegram

Represents the content of the safety telegram sent in the last PROFIsafe cycle.

Parameter 65001 [2]: Error

As a principle, errors are displayed in parameter 65001. They are in connection with the error codes displayed in G1_XIST2:

- 0x0001 Sensor/device error - Bits:

Bit	Definition	0	1
0	Position error (hardware and signal quality)	Position OK	Position error
5	Configuration error	OK	Configuration error
6	Invalid scaling	Scaling parameter OK	Error scaling parameter
11	Master's Sign of Life Fehler	No MSL error	MSL error
22	Memory error	No memory error	Memory error

Parameter 65001 [4]: Warnings

Warnings are also displayed in parameter 65001 - but in subindex 4.

Bit	Definition	0	1
7	Invalid parameters data set in the memory	Valid parameters data set	Invalid parameters data set
12	Overspeed	No overspeed	Overspeed detected
14	Preset failed (preset value outside of range)	OK	Error

Parameter 65004: Function control

The setting of the Function control parameter enables or disables the functionality of the encoder according to the list below.

Bit	Definition	0	1
0	Code sequence	CW	CCW
1	Class 4 functionality	Disabled	Enabled
2	G1_XIST1 Preset control	Enabled	Disabled
3	Scaling function control	Disabled	Enabled
4	Alarm channel control	Disabled	Enabled
5	V3.1 compatibility mode	Unused	Unused
6	Encoder type	Rotary encoder	Linear encoder
7	Reserved		
28 ... 31	Reserved		

Parameter 65005: Parameter control

The setting of the Parameter control parameter enables or disables the access to parameters and special device-related functions according to the list below.

Bit	Definition	0 (default)	1
0 ... 1	Parameter initialization control	Parameter initialization from the PRM data set	Parameter initialization from the internal NV-RAM
2 ... 4	Parameter write protection	Write all: All parameters of the BMP parameter channel can be read and written	Read only: Parameters of the BMP parameter channel can only be read
5	Parameter 65005 Write protection	Write all: Read and write access to P65005 and P971 via the BMP parameter channel	Read only: Only read access to P65005 and P971 via the BMP parameter channel
6	Protection Device reset control	Write all: Read and write access to P972 via the BMP parameter channel	Read only: Only read access to P972 via the BMP parameter channel

Parameter 65006: MUR

Defines the measuring steps per revolution for up to 32-bit values. The max. singleturn resolution of the device must be taken into consideration. ▶ 8]

Parameter 65007: TMR

Defines the total resolution for up to 32-bit values. The max. resolution of the device must be taken into consideration. ▶ 8]

Parameter 65008: MUR

Defines the measuring steps per revolution for up to 64-bit values. The max. singleturn resolution of the device must be taken into consideration. ▶ 8]

Parameter 65009: TMR

Defines the measuring steps per revolution for up to 64-bit values. The max. resolution of the device must be taken into consideration. ▶ 8]

Parameter 65100 [2]: Error

Bit	Definition	0	1
3	Safety Exception	Safety Functions OK	Safety Functions fault
4	Safety Parametrisation	Safety Functions OK	Safety Functions fault
9	PROFIsafe	No PROFIsafe fault	PROFIsafe fault
16	Undervoltage	No Undervoltage fault	Undervoltage fault

Parameter 65100 [4]: Warnings

Bit	Definition	0	1
12	Overspeed	No overspeed	Overspeed warning

5.4.1.3 General Module Parameters

The encoder has various parameters, which can be set likewise in the respective header module, module (slot), subslot and telegram. While the device type-independent general parameters are located at header module level, the device/telegram-specific parameters are located at module, respectively telegram level. Basically, all parameters can be classified as follows:

1. Standard / general parameters
These parameters are present for all devices. They include e.g. the transmission cycle, MRP settings, the startup mode, etc.
2. iParameters
These parameters are individual for every device type and cannot be predetermined only by the GSDML file. For encoders, they include mainly the parameters TMR , MUR, direction of rotation, etc
3. F-parameters
The F-parameters relate exclusively to failsafe devices, i.e. devices that support PROFIsafe. They include e.g. the F-destination address, the F-watchdog time and the F-parameters CRC.

The parameters supported by the device are listed below.

5.4.1.3.1 iParameters

Non-safe telegrams 81, 82, 83, 84, 86, 88

CODE SEQUENCE COUNTER CLOCKWISE

Influences the counting behavior depending on the direction of rotation. Looking at the shaft side of the encoder:

- CW: The encoder position increases for clockwise shaft rotation.
- CCW: The encoder position increases for counter-clockwise shaft rotation.

CLASS 4 FUNCTIONALITY

Influences the consideration of scaling, preset and direction of rotation setting in all telegrams and in position data G1_XIST1, 2 and 3:

- Disabled: Application class 3 - Scaling, preset and direction of rotation setting disabled.
- Enabled: Application class 4 - Scaling, preset and direction of rotation setting enabled.

DISABLE G1_XIST1 PRESET CONTROL

Influences the consideration of the preset (0xB02E):

NOTICE	Effect of G1_XIST1 Preset Control
	<p>This parameter only controls the consideration of the preset for G1_XIST1. If the option is active, the preset will thus not be considered.</p> <p>The execution of a preset on G1_XIST2 and G1_XIST3 is always considered.</p>

- Disabled: G1_XIST1 displays the current position, taking into consideration the preset (G1_XIST1 = G1_XIST2, but without possible error code).
- Enabled: G1_XIST1 displays the current position without taking into consideration the preset.

NOTICE	Position value G1_XIST1
	<p>If G1_XIST1 is disabled and if the position value increases above the maximum value or falls below 0, the device outputs the maximum position value within the scaled total range as position value G1_XIST2.</p> <p>Position value G1-XIST1 is not limited to the scaled total range. For position value G1-XIST1, the device goes on issuing a scaled position value within the total measuring range, e. g. max. 33554432 position for 25 bits.</p>

SCALING FUNCTION CONTROL

Influences the consideration of the scaling:

- Disabled: The position is represented in the maximum possible total resolution (ST+MT = TMR) of the respective used telegram.
- Enabled: The encoder position is represented scaled (according to MUR and TMR).

MUR – MEASURING UNITS PER REVOLUTION

Sets the number of different positions per revolution. This depends on the resolution of the used device and on the maximum permitted number of bits of the used telegram.

Std.Tel.	MUR max. [bits]	TMR max. [bits]	Max. permitted bits acc. to telegram
81, 82, 83, 84,86	20	32	32
88	24	36	64

TMR – TOTAL MEASURING RANGE

Total number different from the positions to be issued, over all revolutions to be differentiated. Here:

- $TMR / MUR = 1 \rightarrow$ Singleturn
- $MUR > TMR$ also possible

Example

✓ MUR = 8192

a) TMR = 65536

⇒ TMR is reached after 8 revolutions, so the positions 0 to 65535 are repeated every 8 revolutions.

Max. MASTER SIGN OF LIFE failures

Maximum number of master sign-of-life failures that can be tolerated.

Values range: 0 ... 255

VELOCITY VALUE NORMALIZATION

This setting affects the unit of the calculated velocity. As a general rule, calculation takes place once per second.

Velocity unit	Value
Steps/s	0
Steps/100ms	1
Steps/10ms	2
RPM	3
N2/N4 normalized	4

PRESET value

Determines an absolute or relative position that can be used when performing a preset, e. g. by standard telegram 81.

Permissible values range:

- Absolute preset: 0...("TMR"-1)
- Relative preset: 0...+/-("TMR"-1)

N2/N4 VELOCITY REFERENCE VALUE

This parameter defines the unit of the actual velocity values. The unit relates to the values NIST_A and NIST_B

Permissible range:

-9000..-1, 1..9000

Parameter Control

Parameter initialization control (P65 005)

Encoder Parameters [▶ 66] Parameter 65005 description

Parameter write protect (P65 005)

Encoder Parameters [▶ 66] Parameter 65005 description

Parameter 65 005 and 971 write protect (P65 005)

Encoder Parameters [▶ 66] Parameter 65005 description

Reset control write protect (P65 005)

Encoder Parameters [▶ 66] Parameter 65005 description

Safe telegrams 36, 37

CODE SEQUENCE COUNTER CLOCKWISE

Influences the counting behavior depending on the direction of rotation. Looking at the shaft side of the encoder:

- CW: The encoder position increases for clockwise shaft rotation.
- CCW: The encoder position increases for counter-clockwise shaft rotation.

S_XIST32 PRESET CONTROL

Influences the consideration of the preset:

- Enabled: S_XIST32 considers a preset operation.

- Disabled: S_XIST32 displays the current position without taking into consideration the preset operation.

SCALING FUNCTION CONTROL

Influences the consideration of the scaling:

- Disabled: The position is represented in the maximum possible total resolution (ST+MT = TMR) of the respective used telegram.
- Enabled: The encoder position is represented scaled (according to the individual settings of MUR and TMR).

NOTICE	Effect of the disabling of the Scaling Function Control
	As soon as Scaling Function Control is disabled, the maximum values must be input in fields TMR and MUR.

NOTICE	Scaling and velocity
	Unlike the non-safe velocity value, the safe velocity value always relates to the unscaled singleturn position, also if an active scaling has been set for the positionnvalue.

MUR – MEASURING UNITS PER REVOLUTION

Sets the number of different positions per revolution. This depends on the resolution of the used device and of the maximum permitted number of bits of the used telegram.

Std.Tel.	MUR max. [bits]	TMR max. [bits]	Max. permitted bits acc. to telegram
36, 37	15	27	32

TMR – TOTAL MEASURING RANGE

Total number different from the positions to be issued, over all revolutions to be differentiated. Here:

- $TMR / MUR = 1 \rightarrow$ Singleturn
- $MUR > TMR$ also possible

With scaling via. USF

- $TMR / MUR =$ decimal or power of 2

Example

- ✓ MUR = 8192
- a) TMR = 65536

⇒ TMR is reached after 8 revolutions, so the positions 0 to 65535 are repeated every 8 revolutions.

VELOCITY MEASURING UNIT

This setting affects the unit of the calculated velocity. As a general rule, calculation takes place once per second.

- 0 = Steps (positions) / second or
- 1 = Steps (positions) / 0.1 second or
- 2 = Steps (positions) / 0.01 second or
- 3 = Revolutions / minute

5.4.1.3.2 F-parameters

The implemented F-parameters are listed below. They exclusively relate to the safety-oriented functions of the device. An additional CRC must be generated for the iParameters of the device. It is generated by the Kübler TCI tool.

NOTICE	Testmode F_iPar_CRC = 0
	The PROFIsafe test mode with CRC = 0 is not supported.

Parameter	BP	XP	Data type	Permission	Value / Description	Default
F_SIL	x	x	Bit	modifiable	SIL1, SIL2, SIL3, no SIL	SIL3
F_CRC_Length	x	-	Bit	not modifiable	3-byte CRC	-
	-	x	Bit	not modifiable	4-byte CRC	-
F_Block_ID	x	x	Bit	not modifiable	1: F_iPar_CRC is required	
F_Par_Version	x	x	Bit	not modifiable	1: V2-Mode	
F_Source_Add	x	x	Uint16	modifiable	Source address Range: 1-65534	1
F_Dest_Add	x	x	Uint16	modifiable	Target address Range: 1-65534	1
F_WD_Time	x	x	Uint16	modifiable	Watchdog time Range: 10-65535 ms	150
F_iPar_CRC	x	x	Uint32	modifiable	CRC iParameters Range: 0-4294967295	-
F_Par_CRC	x	x	Uint16	modifiable	CRC of the F-parameters Range: 0-65535	-
F_Passivation		x	Bit	not modifiable	Device/Module	-
F_CRC_Seed		x	Bit	not modifiable	CRC-Seed24/32	-

F_SIL

Indicates the SIL the user wants to implement with the F-device. The manufacturer defines which SIL can be achieved.

F_CRC_Length

Defines the transferred CRC length in the start-up phase. The CRC length has been adapted since PROFIsafe v2.6.1. The CRC lengths of 3 bytes (PROFIsafe V2.4) and 4 bytes (PROFIsafe V2.6.1) are supported.

F_Block_ID

The preset value of this parameter is 1 = F_iPar_CRC and cannot be changed.

F_Par_Version

This parameter indicates the implemented PROFIsafe version.

"V2-Mode" means that the device supports a PROFIsafe Version > v2. This value is preset and cannot be changed.

F_Source_Add / F_Dest_Add

F_Source_Add defines the PROFIsafe source address, F_Dest_Add defines the PROFIsafe destination address.

Within the safety-oriented application, the PROFIsafe destination address must match with the address defined in the device. The address can be freely selected in the address space of 1 ... 65534.

Standard value F_Source_Add = 1

Standard value F_Dest_Add = 1

NOTICE	Uniqueness of the PROFIsafe address
	<p>Unlike the standard PROFINET, the uniqueness of the PROFIsafe device is not determined by the name or the MAC, but only by the PROFIsafe destination address. This corresponds to the PROFIsafe address type 1.</p> <p>The PROFIsafe source address has no influence on the uniqueness of the PROFIsafe address. The PROFIsafe destination address must always be unique throughout the whole PLC (includes all F-peripherals assigned to a F-CPU) or throughout the network and therefore across subnets.</p>

F_WD_Time

Defines the monitoring interval in [ms]. If no valid safety telegram arrives from the F-host within this period of time, the measuring system is set in the safe state.

NOTICE	Definition of the F_WD_Time
	<p>The watchdog time must be defined, considering the telegram runtimes, so that the usual communication time is tolerated and that, in the event of a failure, the failure reaction function can be performed quickly enough.</p>

F_iPar_CRC

Represents the checksum value (CRC3) calculated from all iParameters of the device. It is merely used to ensure the safe transmission of the iParameters.

The value of this parameter is generated automatically by the Kübler TCI tool. This can be done directly from the automation software.

F_Par_CRC

Represents the checksum value (CRC1) calculated from all F-parameters of the measuring system. It is merely used to ensure the safe transmission of the F-parameters.

Calculation takes place externally, in the engineering tool of the F-host and must then be input under this parameter, or it is generated automatically.

F_CRC_Seed / F_Passivation

Allows the configuration according to PROFIsafe-Version V2.4 or V2.6.

This means that, if the bits are set to 0, the safety-oriented data is transmitted using the PROFIsafe Basic-Protocol (BP) V2.4.

If the bits are set to 1, the safety-oriented data is transmitted using the PROFIsafe Expanded Protocol (XP).

5.4.2 I&M Data

The encoder supports I&M. 0...4 , according to Encoder Profile V4.2 and IEC 61158-6-10 (PROFINET). Access takes place via a record read with index 0xAFF0 or TIA module GET_IM_DATA Reading the I&M data.

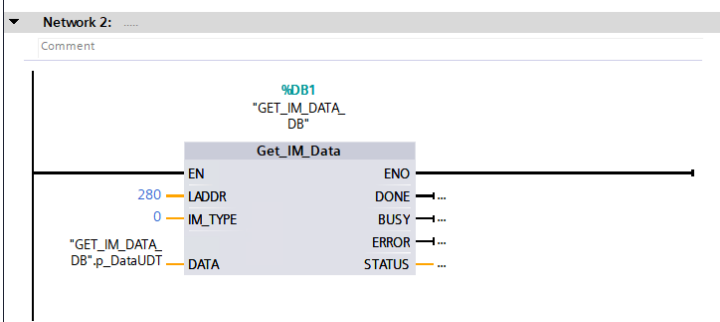

IMG-ID: 184227467

These include the basic device parameters relating to PROFINET and to the manufacturer identification.

The standard I&M 0 data is defined in the data block below.

I&M 0 Data Block

Data block	Data	Data type	Content (example)
Block Header	Block Type	UINT16	0x0020
	Block Length	UINT16	0x0038
	Block Version High	UINT8	0x01
	Block Version Low	UINT8	0x00
I&M Block	Manufacturer-ID	UINT16	0x0198 (Kübler)
	Order_ID	STRING	„8.S58X8FS3“
	Serial Number	STING	„12345678“
	Hardware Revision	STRING	„6“
	Software Revision	STRING	„V1.0.0“
	Revision Counter	UINT16	0x0000
	Profile-ID	UINT16	0x3D00
	Profile Specific Type	UINT16	0x0001
	I&M Version (major)	UINT8	0x01
	I&M Version (minor)	UINT8	0x01
I&M Supported	UINT16	0x000E	

Further I&M data can be saved in addition to the standard I&M 0 data.

These are:

1. I&M 1 = Plant identification and location definition
2. I&M 2 = Installation date
3. I&M 3 = Additional manufacturer-specific information in the device
4. I&M 4 = PROFIsafe information

The I&M data can also be found in TIA Portal, directly in the device. It can be read and adapted in the respective device in the Inspector window, under Properties/General/Catalog information or under Properties/General/Identification & Maintenance”.

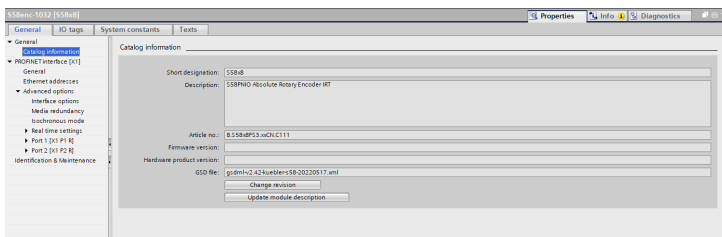

IMG-ID: 250068491

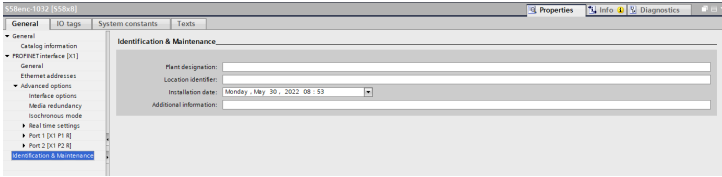

IMG-ID: 250066827

5.4.3 Acyclic Data Transmission

The acyclic data transmission allows reading information from the encoder and writing parameter data in the encoder.

All encoder parameters are referenced by reference numbers, the so-called **PARAMETER NUMBERS - PNU**.

They can be accessed via **RECORD DATA OBJECTS**, which communicate via **PAP** with the **Parameter Manager**.

The encoder profile is always located on slot 1.

Acyclic parameters (base mode parameters) are transmitted via subslot 1 (MAP).

Non-safe iParameters are transmitted via subslot 2.

Safe iParameters and F-parameters are transmitted via subslot 3.

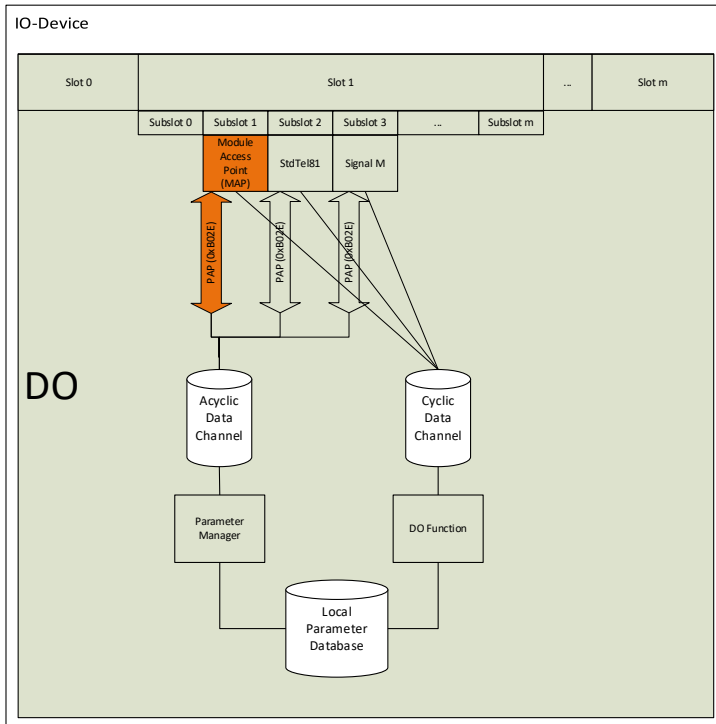

IMG-ID: 179485195

According to the area, PROFINET provides different access possibilities.

RECORD DATA OBJECT	Parameter access service	Slot	Subslot
0xAFF0	I&M 0 parameters	0x01	0x01
0xAFF1	I&M 1 parameters		
0xAFF2	I&M 2 parameters		
0xAFF3	I&M 3 parameters		
0xAFF4	I&M 4 parameters		
0xB02E	Base Mode Parameter Access	0x01	0x01
0xBF00	Start-up Configuration	0x01	0x01

With Siemens PLCs (S7), the "standard blocks" can be used for acyclic communication.

- SFB52=RDREC (READ RECORD)
- SFB53=WRREC (WRITE RECORD)

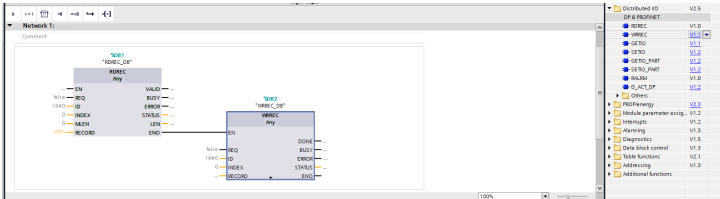

IMG-ID: 180363659

The function blocks implement the BASE MODE PARAMETER ACCESS 0xB02E. The readable parameters are listed in the relevant chapter. See Encoder Parameters, PROFIdrive Parameters.

5.5 Telegrams Description

5.5.1 Available Submodules / Telegrams

Depending on the encoder, different submodules are available to the user.

Submodule / Telegram	Sendix S58XX (Encoder Profile V4.2)	Number of input data words	Number of output data words
StdTel36	X	4	3
StdTel37	X	3	3
StdTel81	X	2	6
StdTel82	X	7	2
StdTel83	X	8	2
StdTel84	X	10	2
StdTel86	X	4	2
StdTel88	X	6	4

NOTICE	Respect the input and output data convention
	The description of the input and output data is always based on the viewpoint of the controller (PLC). Input data is sent from the encoder to the controller. Output data is sent from the controller to the encoder.

Depending on the module, input and output data is defined for the module, which is either transmitted or received and processed by the encoder. The overview describes the composition of the single telegrams with their content - indicated in data words.

Input data words

Submodule / Telegram	0	1	2	3	4	5	6	7	8	9
StdTel36	S_ZSW1_ENC NC	S_NIST16	S_XIST32							
StdTel37	S_ZSW1_ENC NC	S_XIST32								
StdTel81	ZSW2_ENC	G1_ZSW	G1_XIST1	G1_XIST2						
StdTel82	ZSW2_ENC	G1_ZSW	G1_XIST1	G1_XIST2		NIST_A				
StdTel83	ZSW2_ENC	G1_ZSW	G1_XIST1	G1_XIST2		NIST_B				
StdTel84	ZSW2_ENC	G1_ZSW	G1_XIST3			G1_XIST2		NIST_B		
StdTel86	G1_XIST1		NIST_B							
StdTel88	G1_XIST3			NIST_B						

Output data words

Submodule / Telegram	0	1	2	3
StdTel36	S_STW1_ENC	S_PRESET32		
StdTel37	S_STW1_ENC	S_PRESET32		
StdTel81	STW2_ENC	G1_STW		
StdTel82	STW2_ENC	G1_STW		
StdTel83	STW2_ENC	G1_STW		
StdTel84	STW2_ENC	G1_STW		
StdTel86	G1_XIST_PRESET_B			
StdTel88	G1_XIST_PRESET_C			

The exact structure of the telegrams can be found in the respective descriptions. See Telegrams Description.

5.5.2 Submodule - StdTel36 (Encoder Profile V4.2)

Standard data format according to Encoder Profile V4.2

Structure

Index (byte)	0 ... 1	2 ... 3	4 ... 5	6 ... 7
Input	S_ZSW1_ENC	S_NIST16		S_XIST32
Output	S_STW1_ENC		S_PRESET32	

Input data

IO Data (word)	0		1		2		3	
IO Data (byte)	0	1	2	3	4	5	6	7
Actual Value	S_ZSW1_ENC		S_NIST16		S_XIST32			

Output data

IO Data (word)	0		1		2	
IO Data (byte)	0	1	2	3	4	5
Setpoint	S_STW1_ENC		S_PRESET32			

5.5.3 Submodule - StdTel37 (Encoder Profile V4.2)

Standard data format according to Encoder Profile V4.2

Structure

Index (byte)	0 ... 1	2 ... 3	4 ... 5
Input	S_ZSW1_ENC		S_XIST32
Output	S_STW1_ENC		S_PRESET32

Input data

IO Data (word)	0	1	2
IO Data (byte)	0	1	2 3 4 5
Actual Value	S_ZSW1_ENC		S_XIST32

Output data

IO Data (word)	0	1	2
IO Data (byte)	0	1	2 3 4 5
Setpoint	S_STW1_ENC		S_PRESET32

5.5.4 Submodule - StdTel81 (Encoder Profile V4.2)

Standard data format according to Encoder Profile V4.2

Structure

Index (byte)	0...1	2...3	4...7	8...11
Input	ZSW2_ENC Encoder status word	G1_ZSW Sensor status word	G1_XIST1 Actual position 1	G1_XIST2 Actual position 2
Output	STW2_ENC Encoder control word	G1_STW Sensor control word		

Input data

IO Data (word)	0	1	2	3	4	5						
IO Data (byte)	0	1	2	3	4	5	6	7	8	9	10	11
Setpoint	ZSW2_ENC		G1_ZSW	G1_XIST1			G1_XIST2					

Output data

IO Data (word)	0	1			
IO Data (byte)	0	1	2	3	
Setpoint	STW2_ENC		G1_STW		

NOTICE	Preset value
	Unlike StdTel86, the preset value is transmitted cyclically with StdTel81. For the value itself, this means that it is not transmitted in the submodule or in the telegram, but that it uses a variable. This variable has the designation 0xB02E and it can be defined in the general settings of the submodule. See Telegram - Base Mode Parameter Access.

5.5.5 Submodule - StdTel82 (Encoder Profile V4.2)

Standard data format according to Encoder Profile V4.2.

Structure

Index (byte)	0...1	2...3	4...7	8...11	12...13
Input	ZSW2_ENC Encoder status word	G1_ZSW Sensor status word	G1_XIST1 Actual position 1	G1_XIST2 Actual position 2	NIST_A Speed
Output	STW2_ENC Encoder control word	G1_STW Sensor control word			

Input data

IO data (word)	0	1	2	3	4	5	6							
IO data (byte)	0	1	2	3	4	5	6	7	8	9	10	11	12	13
Set point	ZSW2_ENC		G1_ZSW		G1_XIST1			G1_XIST2			NIST_A			

Output data

IO data (word)	0			1		
IO data (byte)	0		1	2		3
Set point	STW2_ENC			G1_STW		

5.5.6 Submodule - StdTel83 (Encoder Profile V4.2)

Standard data format according to Encoder Profile V4.2.

Structure

Index (byte)	0...1	2...3	4...7	8...11	12...15
Input	ZSW2_ENC Encoder status word	G1_ZSW Sensor status word	G1_XIST1 Actual position 1	G1_XIST2 Actual position 2	NIST_B Speed
Output	STW2_ENC Encoder control word	G1_STW Sensor control word			

Input data

IO data (word)	0	1	2	3	4	5	6	7								
IO data (byte)	0	1	2	3	4	5	6	7	8	9	10	11	12	13	14	15
Set point	ZSW2_ENC	G1_ZSW	G1_XIST1	G1_XIST2	NIST_B											

Output data

IO data (word)	0	1		
IO data (byte)	0	1	2	3
Set point	STW2_ENC	G1_STW		

5.5.7 Submodule - StdTel84 (Encoder Profile V4.2)

Standard data format according to Encoder Profile V4.2.

Structure

Index (byte)	0...1	2...3	4...11	12...15	16...19
Input	ZSW2_ENC Encoder status word	G1_ZSW Sensor status word	G1_XIST3 Actual position 1	G1_XIST2 Actual position 2	NIST_B Speed
Output	STW2_ENC Encoder control word	G1_STW Sensor control word			

Input data

IO data (word)	0	1	2	3	4	5	6	7	8	9										
IO data (byte)	0	1	2	3	4	5	6	7	8	9	10	11	12	13	14	15	16	17	18	19
Set point	ZSW2_ENC	G1_ZSW	G1_XIST3	G1_XIST2	NIST_B															

Output data

IO data (word)	0	1		
IO data (byte)	0	1	2	3
Set point	STW2_ENC		G1_STW	

5.5.8 Submodule - StdTel86 (Encoder Profile V4.2)

Standard data format according to Encoder Profile V4.2.

Structure

Index (byte)	0...3	4...7
Input	G1_XIST1 Actual position 1	NIST_B Speed
Output	G1_XIST_PRESET_B	

Input data

IO data (word)	0	1	2	3				
IO data (byte)	0	1	2	3	4	5	6	7
Set point	G1_XIST1				NIST_B			

Output data

IO data (word)	0	1		
IO data (byte)	0	1	2	3
Set point	G1_XIST_PRESET_B			

5.5.9 Submodule - StdTel88 (Encoder Profile V4.2)

Standard data format according to Encoder Profile V4.2.

Structure

Index (byte)	0...7	8...11
Input	G1_XIST3 Actual position 1	NIST_B Speed
Output	G1_XIST_PRESET_C	

Input data

IO data (word)	0		1		2		3		4		5	
IO data (byte)	0	1	2	3	4	5	6	7	8	9	10	11
Set point	G1_XIST3								NIST_B			

Output data

IO data (word)	0		1		2		3	
IO data (byte)	0	1	2	3	4	5	6	7
Set point	G1_XIST_PRESET_C							

5.5.10 Telegram data

Input data

Data	Data type	Description	Bit	Value	Meaning	Explanation
G1_XIST1	UINT32	Sensor 1 Position value 1	0 ... 31		Position value 32 bits	Current absolute position value with max. 32 bits. Is affected by scaling and preset. The use of the preset can be disabled by "Disable G1_XIST1 Preset Control". By default, only G1_XIST1 is active and displays the scaled position which is set by TMR+MUR.
G1_XIST2	UINT32	Sensor 1 Position value 2 without taking the preset into account	0 ... 31		Position value 32 bits	Current absolute position value with max. 32 bits. Is affected by scaling and preset. G1_XIST2 can be enabled by bit 13 of STW2_ENC. G1_XIST2 then displays the same position as G1_XIST1. In the event of an error, the following error codes are output: 0x0001 Sensor/device error 0x0F01 Syntax error 0x0F02 Master Sign of Life error 0x0F04 Sync error Exact error description see Encoder Parameters.
G1_XIST3	UINT64	Sensor 1 Position value 3	0 ... 63		Position value 64 bits	Current absolute position value with max. 64 bits. Is affected by scaling and preset.

Data	Data type	Description	Bit	Value	Meaning	Explanation
NIST_A	UINT16	Current velocity 16 bits	0 ... 14		Velocity	Current velocity value is affected by scaling and preset. max. ± 15 bits
			15		Sign	0 = + / 1 = -
NIST_B	UINT16	Current velocity 32 bits	0 ... 30		Velocity	Current velocity value is affected by scaling and preset. max. ± 31 bits
			31		Sign	0 = + / 1 = -
G1_ZSW	UINT16	Sensor 1 status word	0 ... 10	0		
			11		Requirement Of Error Acknowledgement Detected	Switches to 1 in the event of an error. Further causes: The controller sets or erases the Sensor Error Acknowledge with bit 15 of G1_STW. Sensor error G1_ZSW bit 15 present and error code in G1_XIST2. Controller erases G1_ZSW bit 15. G1_XIST2 contains again a position value.
			12		Set/Shift Of Home Position Executed	The encoder sets this bit to 1 after completion of a preset operation until the corresponding bit in G1_STW is erased again by the controller.
			13		Transmit Absolute Value Cyclically	Set to 1 when a valid position is present in G1_XIST2. Is 0 when G1_ZSW bit 14 / bit 15 = 1
			14		Parking Sensor Active	Switches to 1 as soon as G1_STW bit 14 is set. In this case, the reported position is fixed.

Data	Data type	Description	Bit	Value	Meaning	Explanation
			15		Sensor Error	Switches to 1 is a hardware error is detected. G1_XIST2 then contains the error code G1_ZSW bit 13 is set to 0. This error bit must be acknowledged via G1_STW bit 15 in order to set G1_ZSW bit 15 to 0. Condition: the error has been corrected.
ZSW2_ENC	UINT16	Status word 2 Encoder	0	0	Idle	The offset value of the latest preset operation is saved. The encoder is ready for a new preset operation.
				1	Preset confirmation	The previously defined preset value has been set as the new actual position value. This is confirmed with the change of the bit from 0 → 1. The value has been saved internally.
			1	0	G1_XISTx invalid	The position value in G1_XIST x is invalid
				1	G1_XISTx valid	The position value in G1_XIST x is valid
			2	0	G1_NISTx invalid	The velocity value in G1_NIST x is invalid
				1	G1_NISTx valid	The velocity value in G1_NIST x is valid
			3	0	No error present	The encoder detected no error.
				1	Error present	The encoder detected one or several errors.
			4 ... 6			Reserved
			7	0	No warnings present	The encoder issued no warning message.
				1	Warnings present	Warning messages are present in the encoder.
			8	0		Reserved
			9	0		No connection with the PLC.
				1		Connection has been established with the PLC.

Data	Data type	Description	Bit	Value	Meaning	Explanation
			10,11			Reserved
			12 ... 15	0 ... 15	Encoder Sign-Of-Life	Sign-of-life of the encoder As soon as the controller sends the master sign-of-life (M-LS), the encoder starts to send its own sign-of-life. This is a signal incremented bit by bit with the values 0 ... 15 The start value is 0.
S_XIST32	UINT32	Safe position word	0 ... 31		Position value 32 bits	Current safe absolute position value with max. 27 bits. Is affected by scaling and preset. The use of the preset can be disabled by "S_XIST32 Preset Control".
S_NIST16	UINT16	Current safe velocity 16 bits	0 ... 14		Velocity	Current safe velocity value. Is not affected by scaling. max. ± 15 bits
S_ZSW1_ENC	UINT16	Safe status word Encoder	0	1	Safe position value is valid	The safe position value S_XIST32 from the encoder is valid.
				0	Safe position value is invalid	The safe position value S_XIST32 from the encoder is invalid.
			1	1	Safe velocity value is valid	The safe velocity value S_NIST_16 from the encoder is valid.
				0	Safe velocity value is invalid	The safe velocity value S_NIST_16 from the encoder is invalid.
			2	1	Safety preset functionality enabled	The preset functionality is enabled
				0	Safety preset functionality disabled	The preset functionality is disabled The PRESET_SET bit has no effect.
			3 ... 4			Reserved

Data	Data type	Description	Bit	Value	Meaning	Explanation
			5	1	Safety preset error	Display of a preset error
				0	Safety preset no error	No preset error
			6		Preset confirmation	The preset value is set as the new actual position value. This is confirmed with the change of the bit from 0 → 1.
			7 ... 15			Reserved

Output data

Data	Data type	Description	Bit	Value	Meaning	Explanation
G1_STW	UINT32	Sensor 1 control word	0 ... 7		Reserved	
			8 ... 10		Reserved	
			11	0	Home Position Mode	Absolute preset (new position = preset value)
				1		Relative preset (new position = old position + preset value)
			12	0	Request Set/Shift Of Home Position	Initial state.
				1		Switching from 0 to 1 triggers a preset operation
			13	0	Request Absolute value Cyclically	Disabled. G1_XIST2 is not transmitted.
				1		Enabled. G1_XIST2 is transmitted.
			14	0	Activate Parking Sensor	Disabled

Data	Data type	Description	Bit	Value	Meaning	Explanation
				1		The controller disables the encoder ("parking"). In this case, bit 14 in G1-ZSW has the value 1. The current position data is frozen. No new errors are issued.
			15	0	Acknowledge Sensor Error	Sensor error transmission disabled.
				1		Sensor error transmission enabled.
STW2_ENC	UINT16	Control word 2 Encoder	0	0	Idle	Before this bit is set, it must have been set to "0" by the PLC.
				1	Trigger preset	Changing this bit from 0 → 1 sets the preset value of G1_XIST_PRESET_x as new actual position value. The actual position value is corrected by a calculated offset value. The offset is saved internally, with confirmation by ZSW2_ENC.bit0.
			1 ... 6			Reserved
			7	0	No meaning	
				1	Error confirmation	Current errors in the error memory are confirmed with a change of the bit from 0 → 1.
			8, 9			Reserved
			10	0	No control by the PLC.	Data is not valid, excepted the sign-of-life. G1_XIST2 is disabled.
				1	Control by the PLC.	Control via the interface, I/O data is valid.
			11			Reserved

Data	Data type	Description	Bit	Value	Meaning	Explanation
			12 ... 15	0 ... 15	Master Sign-Of-Life	<p>Is only required if the isochronous mode is enabled. The encoder expects a bit by bit incrementation of bits 12 ... 15.</p> <p>As soon as the M-LS contains a value different from 0, the encoder starts issuing the encoder LS. As soon as a deviation is detected in the M-LS with respect to the expected count sequence, the errors counter is incremented and, if necessary, error 0x0F02 is issued in G1_XIST2.</p>
G1-XIST_PRESET_B	UINT32	Encoder control word 31 bits with trigger bit	0 ... 30		Preset value	Preset value (31 bits) must be set to G1_XIST1.
			31		Perform preset	Perform the preset operation as soon as bit 31 increases from 0 to 1.
G1-XIST_PRESET_C	UINT64	Encoder control word 63 bits with trigger bit	0 ... 62		Preset value	Preset value (63 bits) must be set to G1_XIST3.
			63		Perform preset	Perform the preset operation as soon as bit 63 increases from 0 to 1.
S_STW1_ENC	UINT16	Safe control word Encoder	0	1	Encoder preset function enabled	<p>Enable preset function</p> <p>When the preset function is enabled by this bit and the preset trigger bit shows a rising edge (0 -> 1) in the same control word, the actual internal position value of the encoder is set to the preset value that is transmitted at this moment in S_PRESET32.</p>
				0	Encoder preset function disabled	The preset trigger has no effect.
			1 ... 5			Reserved

Data	Data type	Description	Bit	Value	Meaning	Explanation
			6		Encoder preset trigger (0 -> 1)	Perform the preset function. When the preset function is enabled and the preset trigger bit shows a rising edge (0 -> 1), the position of the encoder is set to the preset value transmitted in S_PRESET32.
			7 ... 15			Reserved
S_PRESET32	UINT32	Safe position preset value	0 ... 31		Preset value	Preset value to which S_XIST32 is to be set.

5.6 Features Description

5.6.1 Firmware update and reset

The device can be updated and reset by means of a web server. To this purpose, a browser is used to access to the respective IP address of the device.

NOTICE	Web access possibilities
	The PROFINET communication must be disabled to allow access to the web server of the device, since this communication only takes place via TCP/IP. The condition is that the device has a valid IP address.

There are mainly two ways to establish a web access to the device.

1. Direct connection of the IO supervisor / PC to the encoder
2. Deactivate PROFINET participants in the existing network

If you select the second option, e.g. because the direct connection of the device to the PC is not possible, the device must first be deactivated.

Deactivate the device in the active network

- ✓ Make sure that the PROFINET communication to the device operates without errors.
 - a) Implement the standard block “D_ACT_DP” in your process routine
 - b) Assign the required input and output parameters to the block. Details can be found in the block description.

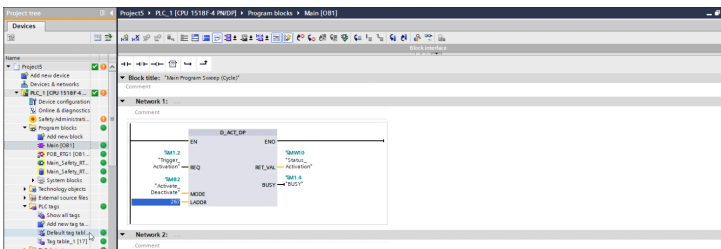

IMG-ID: 306133259

- c) Switch the status of the communication to “RUN”
 - d) Send the command that triggers the block and deactivates the device.
- ⇒ The device is deactivated. This is shown by a gray status symbol. The firmware update can now be carried out.

Call the web server and update the firmware

- ✓ Make sure that the device is connected (through the network) to the PC used for the project.
- ✓ Store the current firmware file in any folder chosen by you.
 - a) Input the IP address of the concerned device in your browser and confirm with Enter.

- ⇒ The FW versions currently installed on the device can be found in the representation of the web server.

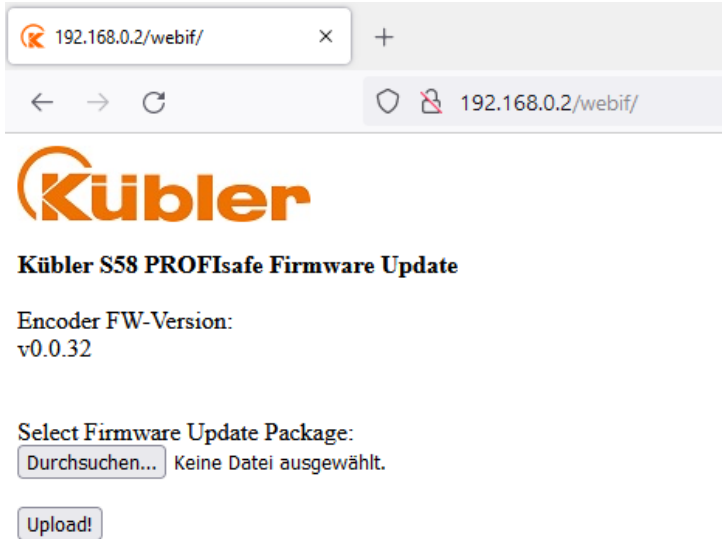

IMG-ID: 250030987

- b) Click on “Upload” to upload the .kbl file.

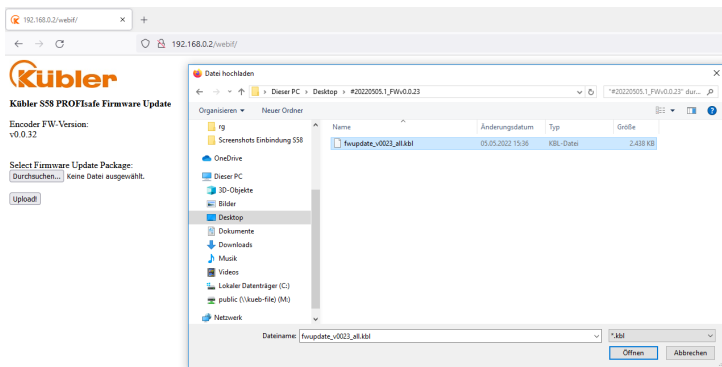

IMG-ID: 250032651

- c) Now click on “Load” to transfer the firmware to the device. This operation can require some minutes.
 - ⇒ The current update steps are displayed in the log line.
 - ⇒ The log line indicates the completion of the FW transfer.

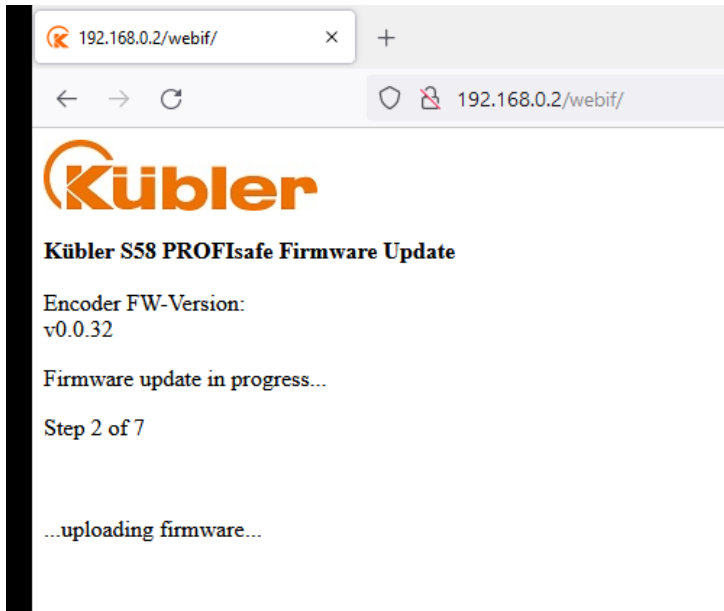

IMG-ID: 250050315

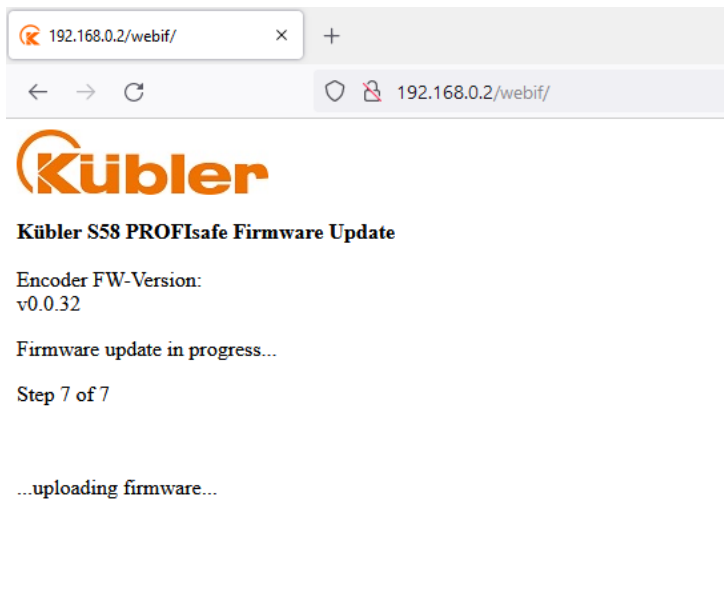

IMG-ID: 250051979

Also refer to

- 📖 Commissioning [▶ 50]

5.6.2 LLDP - Link Layer Discovery Protocol

NOTICE	Use of the feature
	The use of this feature is the same for the S58 and F58 series.

LLDP is an initially manufacturer-independent layer 2 protocol. A device using LLDP sends in a cycle of a few seconds a message to its neighboring devices to identify itself and transmit network-related information.

This information relates to the device and its integration type in the respective topology (port description, IP address, device name, etc.).

As a standard, the LLDP function is always active, but it can be disabled. During startup in the network, all devices exchange this information. This allows recognizing/reconstructing directly the topology in an engineering tool. The main advantage is the simplified replacement of defective devices. A LLDP ALIAS name is automatically assigned to the new device. It can this way log on the network automatically, without using software.

NOTICE	<p>Conditions for device replacement without exchangeable medium – Plug&Play</p> <p>To allow Plug&Play device replacement, it must be made sure that the new PROFINET device has no device name. This is the ex-factory delivery status. In addition, current controllers also allow overwriting existing device names. This must then be set by the controller.</p> <p>Likewise, smooth device replacement without additional parameterizing can only be guaranteed if the old PROFINET device has been projected with telegrams that are also supported in the new device. In the case of 58x8 – StdTel81 /86 or ManTel860.</p> <p>See Available Submodules / Telegrams.</p>
---------------	---

Proceed as follows to allow easy device replacement without exchangeable medium:

- ✓ Make sure that the old device was properly integrated and that the new device is accessible.
 - a) Select the control in the topology view.
 - b) Switch to "Properties / General / Interface options".
 - c) Make sure that item "Support device replacement without exchangeable medium" is checked.
- ⇒ As soon as a device is replaced in the topology with a device without device name, the latter is overwritten with the existing device name and is then ready for operation.

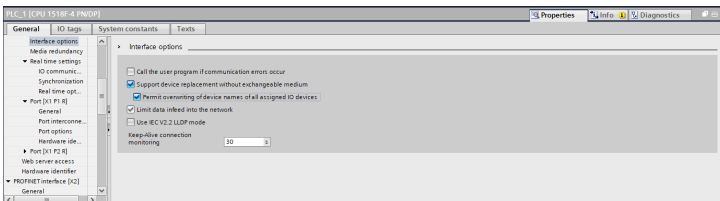

IMG-ID: 184428427

- ✓ If the device already has a PROFINET device name, it can still be overwritten provided the controller supports this function.
- d) For this purpose, select the option "Overwrite the device names of all assigned IO devices".
- ⇒ If devices are to be replaced in the existing topology, the device names are automatically overwritten.

5.6.3 MRP - Media Redundancy Protocol

NOTICE	Use of the feature
	The use of this feature is the same for the S58 and F58 series.

PROFINET offers the possibility of setting up a ring topology. The MRP allows conveying data to the controller using both directions of the logical ring. However, this only takes place in case of need (typically in the event of a cable break) – i. e. as soon as a transmission path stops operating, the second is opened. The changeover generally requires some milliseconds. The MRP is mostly used in connection with RT, but it can also be used with IRT.

Proceed as follows to activate the MRP functionality in the encoder:

- ✓ Make sure that you added the encoder to the topology.
- a) Switch to Device overview.
- b) Switch to "Device settings / Properties / General".
- c) Under Media redundancy, select the "Client" role to be able to use the MRP functionality.
- ⇒ The encoder now uses the MRP functionality.

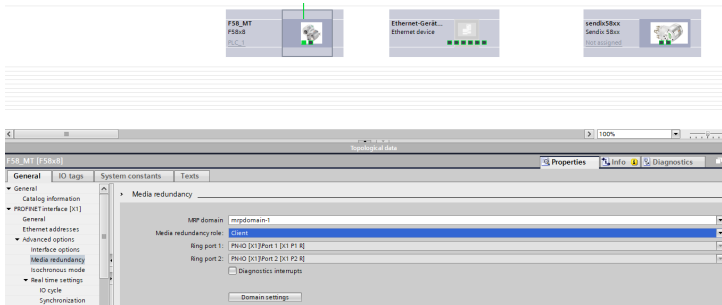

IMG-ID: 184322827

Proceed as follows to activate the MRP functionality in the controller:

- ✓ Make sure that you added all participants to the topology.
- d) Switch to the device overview of the controller.
- e) Switch to "Device settings / Properties / General".
- f) Under Media redundancy, select the "Master (auto)" role to be able to use the MRP functionality.
- ⇒ The whole network now uses the MRP functionality.

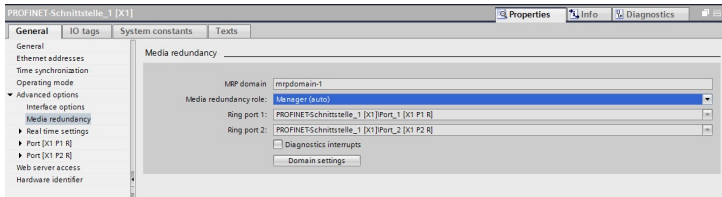

IMG-ID: 179750923

NOTICE	<p>Creation of a logical ring</p> <p>To create a logical ring, all devices must be in the same subnet, i. e. the 3 first octets of the IP address must be identical everywhere. Since this also concerns the PC used to parameterize the controller, and since the controller generally has only 2 ring ports, the use of a switch is recommended.</p>
---------------	---

5.6.4 Isochronous Mode IRT

NOTICE	<p>Use of the feature</p> <p>The use of this feature is the same for the S58 and F58 series.</p>
---------------	---

If the smallest IRT cycle times of the concerned application are not sufficient, such as e. g. in a Motion Control control loop, the isochronous mode can be enabled in addition. This mode ensures that data is deterministic at any time. This means that data is strictly sequenced and follows a specified clock cycle imposed by the controller. The minimum clock cycle is 250 μ s (PROFINET device) or 500 μ s (PROFisafe device – non-safe value). The cycle time can be any multiple of the minimum cycle time. All transmission times for all network participants are calculated in advance. Collisions and latencies due to jitter are excluded by network-side prioritization mechanisms. This allows e.g. assigning the position value obtained by the sensor to an exact moment ($\pm 1 \mu$ s) at which it was measured.

Proceed as follows to activate the Isochronous Mode of the controller:

- ✓ Make sure that the controller has been integrated in the topology and parameterized properly.
- a) Navigate to the Project tree and select "Add new block".
 - ⇒ The "Add new block" window opens.

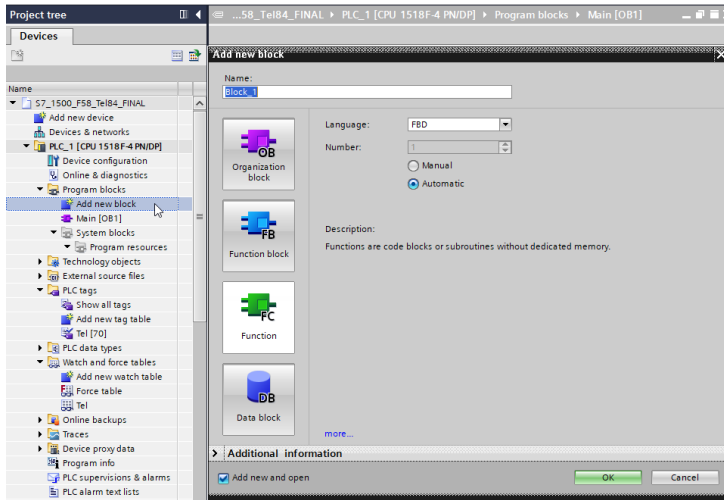

IMG-ID: 185405323

- b) Click on "Organization block" and select the "Synchronous Cycle" block.
- c) Confirm with "OK".
 - ⇒ The block is added to the topology.
- d) Open the newly added "Synchronous Cycle" block.

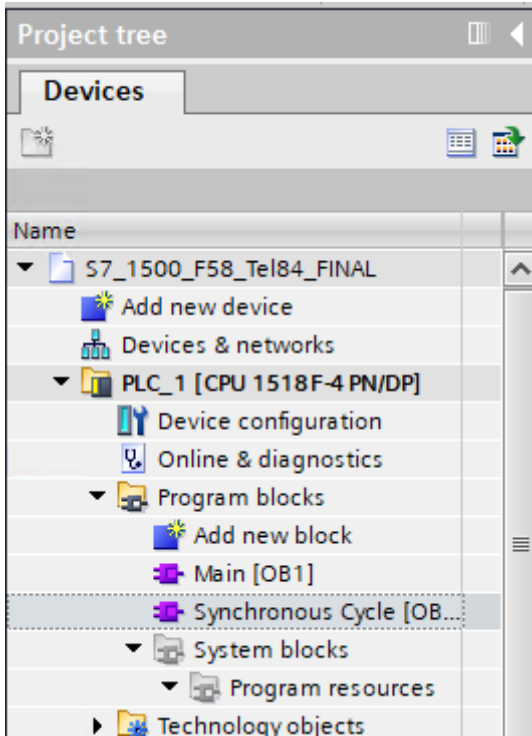

IMG-ID: 185406987

e) Now the functions UPDATE_PI and UPDATE_PO must be added. Drag them on the instructions topology into the block.

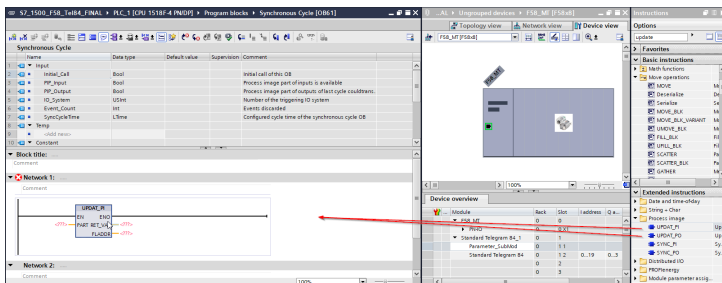

IMG-ID: 185408651

f) The functions consist of one input and two output parameters. Create them according to your data types in the data of the organization block.

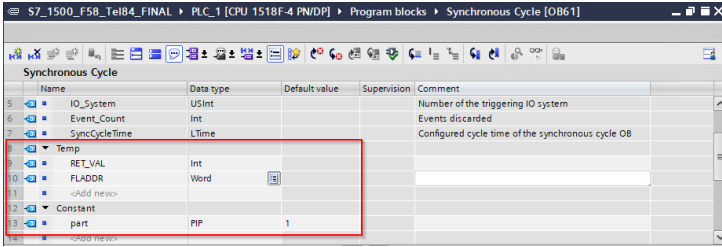

IMG-ID: 185426187

g) Make sure that the default value of variable part = 1. This determines the partition of the process image that is to be updated.

h) Assign these variables to the two functions.

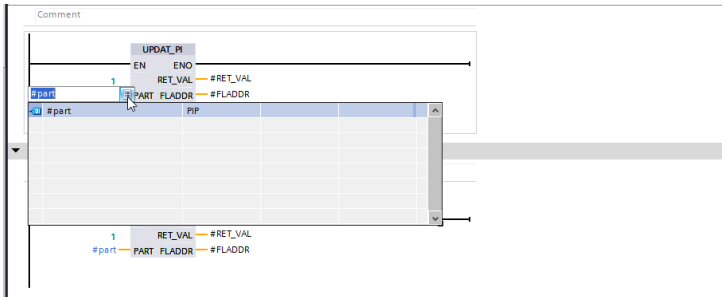

IMG-ID: 185428619

Proceed as follows to activate the IRT functionality of the encoder:

- ✓ Make sure that you added the encoder to the topology.
- ✓ The organization block OB61 Synchronous Cycle must have been added to the controller.

i) Switch to Device overview.

j) In the navigation tree, under "Settings / General", click on "Isochronous mode".

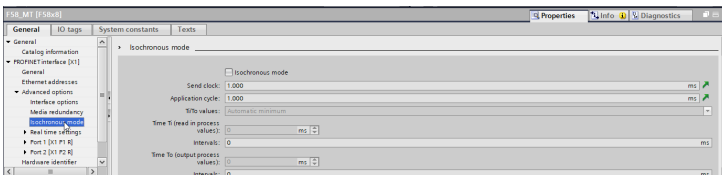

IMG-ID: 185431051

k) Check "Isochronous mode".

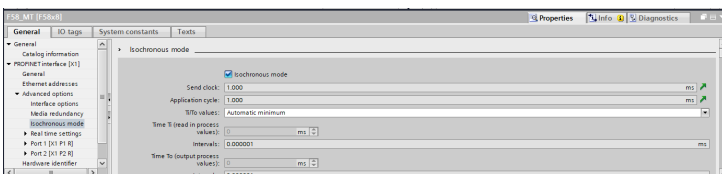

IMG-ID: 185432715

l) Select the desired telegram in the "Detail overview".

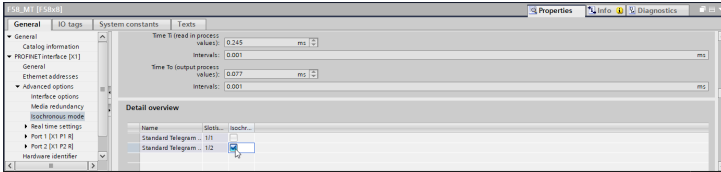

IMG-ID: 185434379

m) The encoder must be activated for the clock rate specification of the controller. for this, navigate to the detail overview of the concerned telegram.

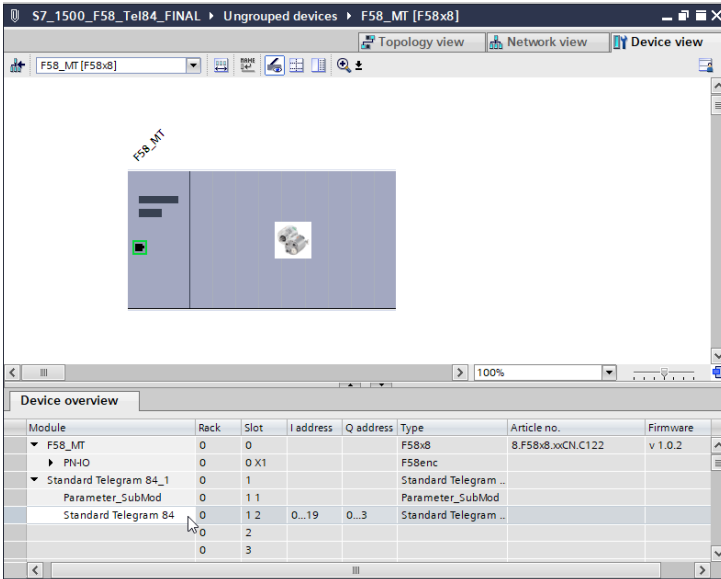

IMG-ID: 185436043

n) Select Settings / General and click on I/O addresses

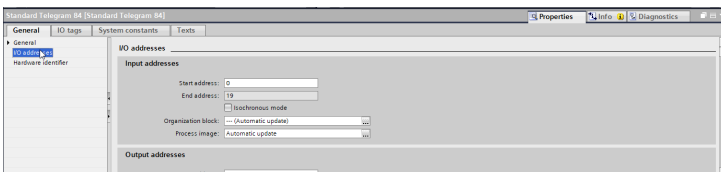

IMG-ID: 185437707

o) Check "Isochronous mode".

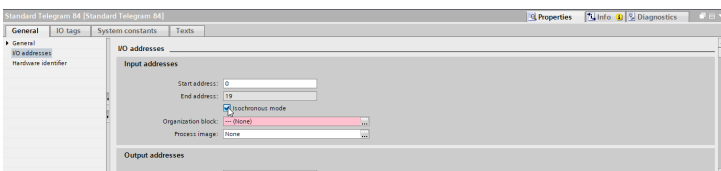

IMG-ID: 185439371

p) Assign the created organization block OB61 to the clock.

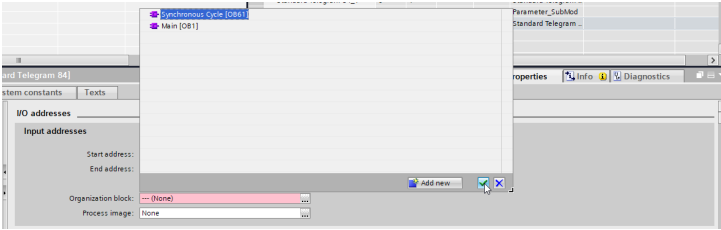

IMG-ID: 185441035

- q) Proceed the same way for the output addresses
 - r) Download the configuration and start the communication.
- ⇒ The device now operates in IRT mode.

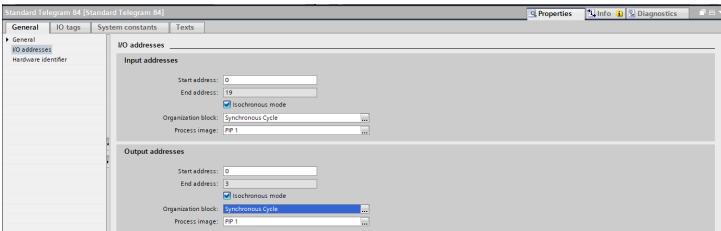

IMG-ID: 185442699

NOTICE	IRT in conjunction with MRP.
	MRP cannot be used associated with IRT. To achieve this, the devices must support MRPD in the ring.

5.6.5 Integrating an Encoder as a Technology Object

NOTICE	Use of the feature
	The use of this feature is the same for the S58 and F58 series.

The encoder can be integrated as a technology object in the project design:

- ✓ Make sure that the encoder is already present in the project.
- a) In the navigation, under "Technology objects", select "Add new object".
 - ⇒ The window "Add new object" opens.

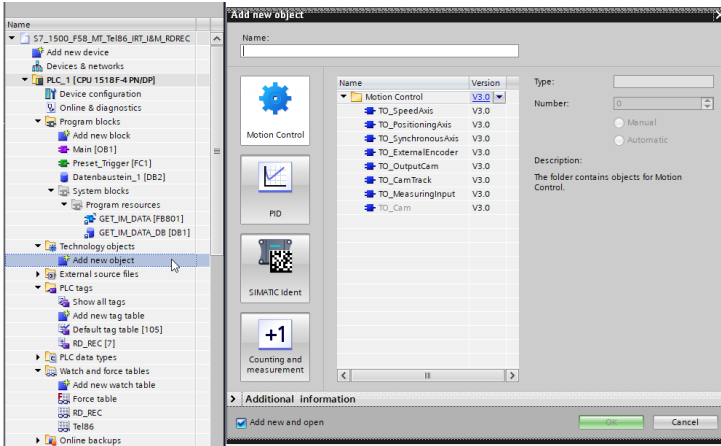

IMG-ID: 184787979

b) In the MOTION CONTROL folder, select object "TO_ExternalEncoder".

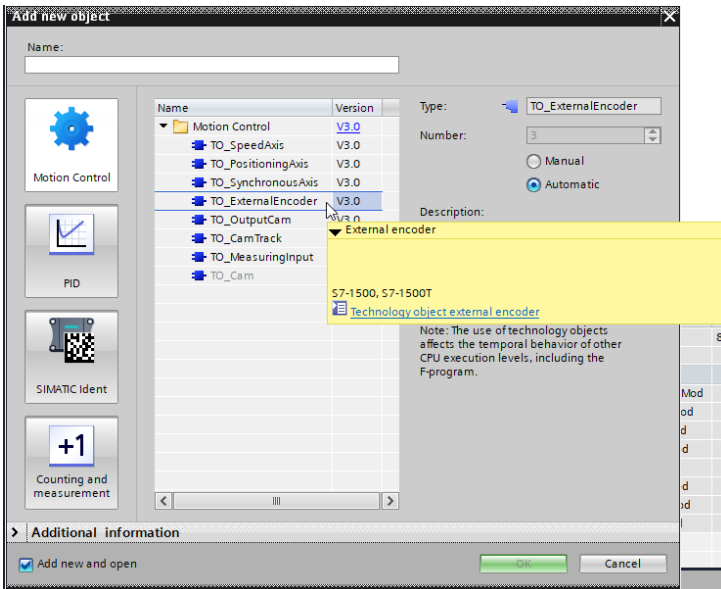

IMG-ID: 184789643

c) Assign a type designation for the encoder in the "Type" field.

d) Confirm with "OK".

⇒ The technology object is displayed in the navigation.

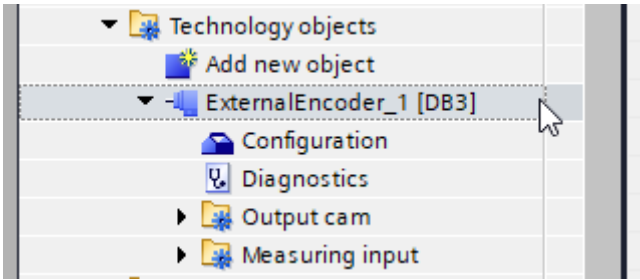

IMG-ID: 184791307

- e) Extend the new created object.
- f) Select "Configuration".

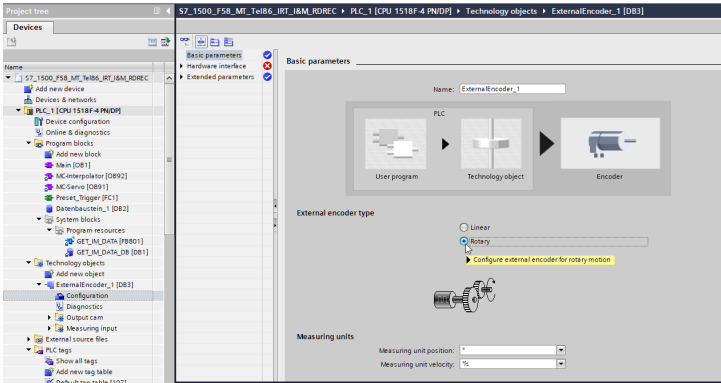

IMG-ID: 184792971

- g) Under "Basic parameters", set the option "Rotary".
 - ⇒ A warning message is displayed. The configured values will be reset to default values.

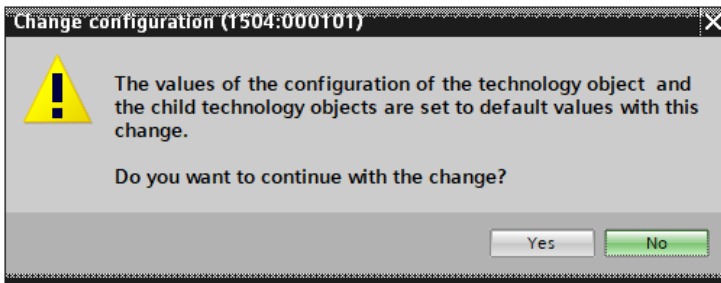

IMG-ID: 184794635

- h) Confirm this message with "Yes".
- i) Select "Hardware interface" and the option "PROFIdrive encoder to PROFINET/PROFIBUS".
- j) Under the selection field, add the encoder known from the GSDML file.

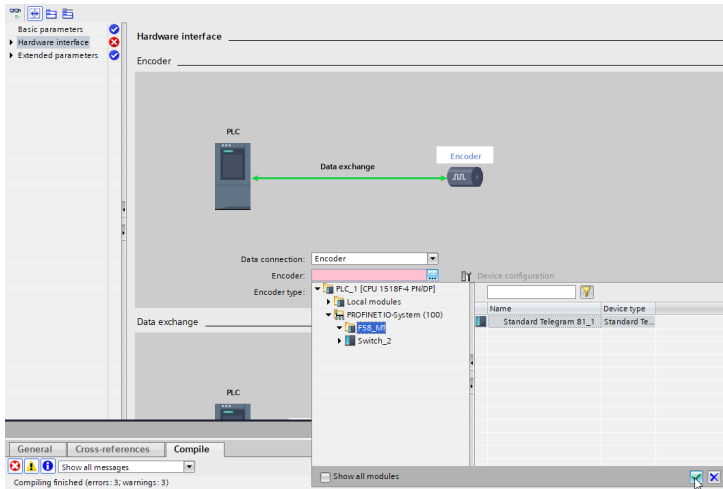

IMG-ID: 184801931

k) Confirm with the green check.

l) The encoder can be parameterized. To do so, select "Data exchange".

m) Under "Telegram", select the same telegram as the one selected when integrating the encoder. Only telegrams 81 and 83 are supported.

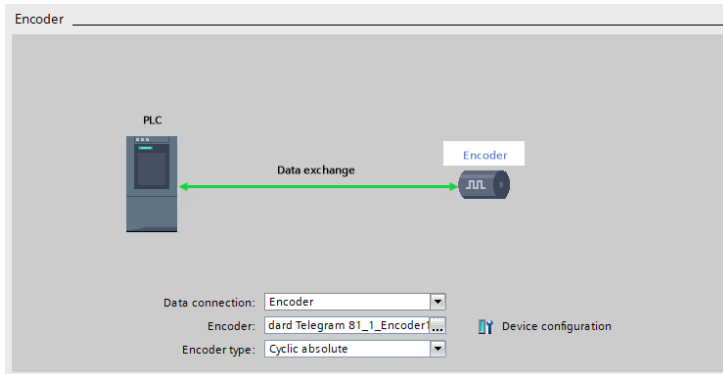

IMG-ID: 194718475

n) Under "Encoder type", select option "Rotary absolute".

o) In "Increments per revolution", input your MUR value (e. g. 524,288) and in field "Numbers of revolutions" the NDR value: 4096 → 19 bits ST / 31 bits TMR.

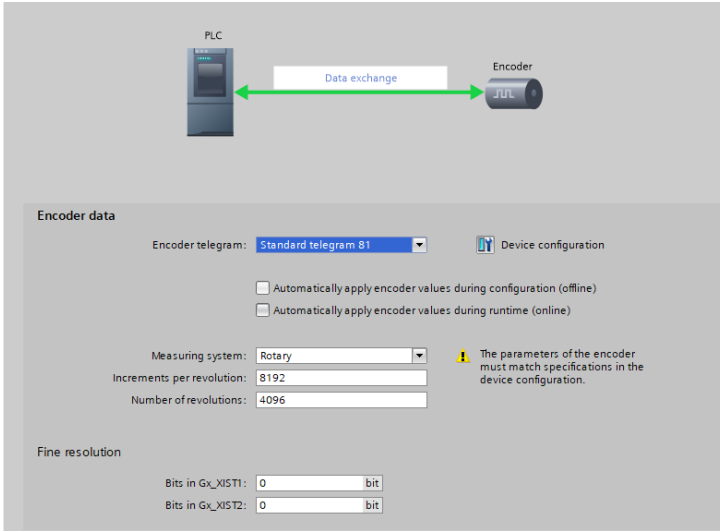

IMG-ID: 253505547

p) For complete encoder parameterization, click on Device configuration.

⇒ The device view opens.

q) Under the used submodule "Properties", "Module parameters", set the desired parameters.

⇒ The encoder is now entirely integrated as a technology object.

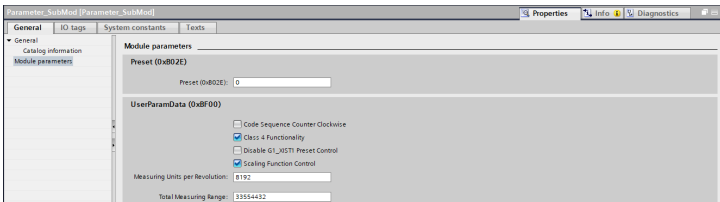

IMG-ID: 253507211

5.7 Diagnostics

5.7.1 Error

NOTICE	Permissible reactions after a device error
	<p>The displayed device error must always first be checked via the diagnostic possibility in the PROFINET. Depending on the error pattern, suitable measures (see table) must be taken to eliminate the error. Switching the power supply off and on again may possibly be necessary.</p>

Value (dec)	Diagnostic message	Description
37120	Position error (hardware and signal quality)	Error in the sensor, possibly corrected by a restart, otherwise replace the encoder
37123	Safety exception	Serious error in the safe program, possibly corrected by a restart, otherwise replace the encoder
37124	Error in the safe parameterizing	Safe parameterizing is faulty, please check the F-parameters and the iParameters
37125	Configuration error	Parameterizing is faulty, please check
37126	Invalid scaling	Error in the scaling parameters, check TMR and MUR
37129	PROFIsafe communication error	Error in the PROFIsafe communication, possibly corrected by a restart, otherwise replace the encoder
37131	Master's Sign of Life Fault	Error in the master's sign of life
37142	Memory error	Error in the internal memory, possibly corrected by a restart, otherwise replace the encoder
37136	Undervoltage	Error due to an undervoltage situation at the power supply line (typically 24 V supply), leading to the failure of the internal voltage supply of the encoder. Check the external power supply for undervoltage problems.
64	Safety destination address mismatch (F_Dest_Add)	Check the parameterizing
65	Safety destination address invalid (F_Dest_Add)	Check the parameterizing
66	Safety source address invalid or mismatch (F_Source_Add)	Check the parameterizing
67	The value of the safety monitoring time is 0 ms (F_WD_Time)	Check the parameterizing, Watchdog time, see chapter TBD
68	Parameter 'F_SIL' exceeds the SIL of the specific device application	Check the parameterizing, F_SIL must correspond to the device application, see chapter TBD
69	Parameter 'F_CRC_Length' does not correspond to the generated values	Check the parameterizing
70	Version of the F-parameters set incorrect	The version of the set F-parameters set does not match with that of the device, the application cannot be run with the encoder.
71	Data inconsistent in the received F-parameters block (CRC1 error)	The calculated checksum of the safety parameters (F-parameters) is wrong, please check again
75	Inconsistent iParameters (iParCRC error)	The calculated checksum of the configuration (iParameters) is wrong, please check again Tool Calling Interface - TCI [▶ 45]
76	F_Block_ID not supported	Check the parameterizing

5.7.2 Warnings

Value (dec)	Diagnostic message	Description
37127	Invalid parameters data set in the memory	Invalid values are set in the Base Mode Parameters data set e. g. values outside the measuring range, check and correct the parameters data set
37132	Maximum velocity exceeded	Maximum velocity exceeded, reduce the velocity
37134	Preset error	Preset value outside the valid range, please check the value

5.8 Examples

5.8.1 Reading the I&M data

Proceed as follows to read the I&M data:

- ✓ Make sure that the encoder has been created in the project design tool and is accessible (the example refers to TIA Portal).
- a) Navigate to the main routine of the controller.
- b) Here, create block `Get_IM_Data`.

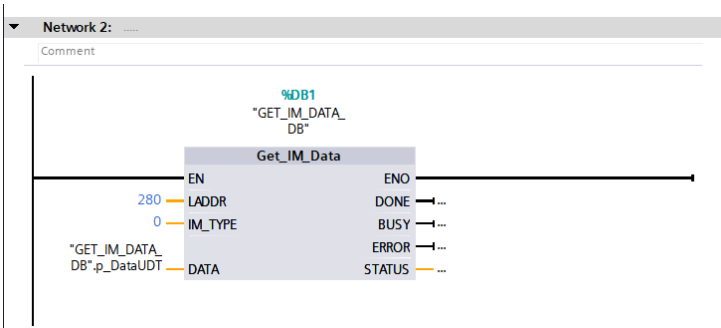

IMG-ID: 184253707

- c) Save the proper hardware identifier in parameter `LADDR`. It can be found in the relevant device under `Properties / General / Hardware identifier`.

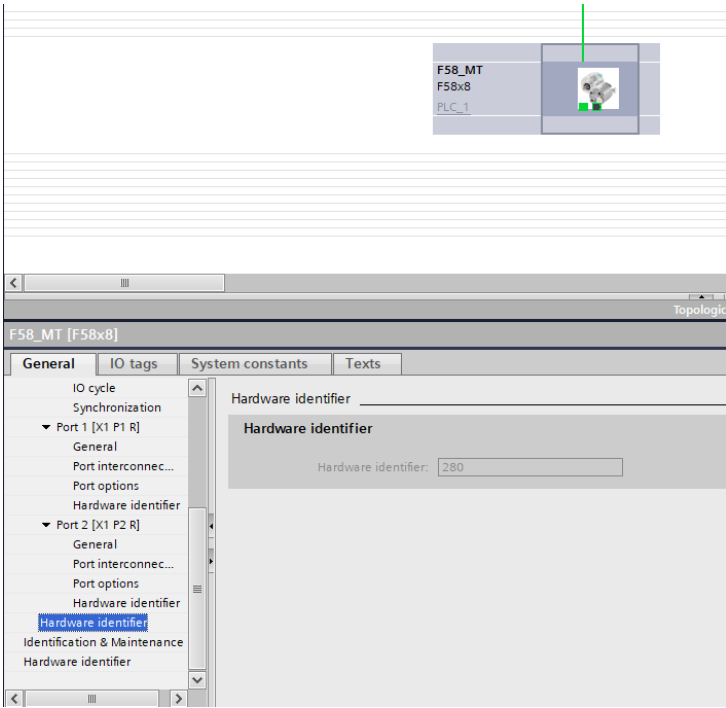

IMG-ID: 184250123

- d) For IM_TYPE, save the desired I&M type (I&M 0...3). In this example, the I&M 0 data is to be read.
 - e) Finally, select the output range. This is a structure that is created automatically with the block. It contains the single variables assigned to the respective I&M 0 parameters. See I&M Data.
- ⇒ The I&M 0 data is now read and can be found in the data set of the block.

The screenshot shows the variable declaration table for the 'GET_IM_DATA_DB' block. The table lists various variables with their data types, start values, monitor values, and other properties.

Name	Data type	Start value	Monitor value	Return	Accessible f.	Visible in ...	Supervision	Comment
idc_IndustrialCom_pwrts	Unit	0	0		<input type="checkbox"/>	<input type="checkbox"/>	<input type="checkbox"/>	
idc_Pos	Out	0	0		<input type="checkbox"/>	<input type="checkbox"/>	<input type="checkbox"/>	
idc_Max	Int	0	768		<input type="checkbox"/>	<input type="checkbox"/>	<input type="checkbox"/>	
idc_Reserved	Bool	False	False		<input type="checkbox"/>	<input type="checkbox"/>	<input type="checkbox"/>	
pin_TemporaryWord	Word	1640	164000E		<input type="checkbox"/>	<input type="checkbox"/>	<input type="checkbox"/>	
pin_SingleByte	AnyOf(8) of Byte				<input type="checkbox"/>	<input type="checkbox"/>	<input type="checkbox"/>	
pin_DataChar	AnyOf(8) of Char				<input type="checkbox"/>	<input type="checkbox"/>	<input type="checkbox"/>	
pin_DataString	String(254)				<input type="checkbox"/>	<input type="checkbox"/>	<input type="checkbox"/>	
pin_TemporaryCharacter	AnyOf(16) of Char				<input type="checkbox"/>	<input type="checkbox"/>	<input type="checkbox"/>	
pin_DataOut	IM0_Data				<input type="checkbox"/>	<input type="checkbox"/>	<input type="checkbox"/>	
Manufacturer_ID	Unit	0	408		<input type="checkbox"/>	<input type="checkbox"/>	<input type="checkbox"/>	
Order_ID	String(20)		8F88B4081C72...		<input type="checkbox"/>	<input type="checkbox"/>	<input type="checkbox"/>	
Serial_Number	String(16)		2104102471		<input type="checkbox"/>	<input type="checkbox"/>	<input type="checkbox"/>	
Hardware_Revision	Unit	0	6		<input type="checkbox"/>	<input type="checkbox"/>	<input type="checkbox"/>	
Software_Revision	IM0_Version				<input type="checkbox"/>	<input type="checkbox"/>	<input type="checkbox"/>	
Revision_Counter	Unit	0	0		<input type="checkbox"/>	<input type="checkbox"/>	<input type="checkbox"/>	
Profile_ID	Unit	0	15816		<input type="checkbox"/>	<input type="checkbox"/>	<input type="checkbox"/>	
Profile_SpecAC_3	Unit	0	3		<input type="checkbox"/>	<input type="checkbox"/>	<input type="checkbox"/>	
IM_Version	Word	1640	1640101		<input type="checkbox"/>	<input type="checkbox"/>	<input type="checkbox"/>	
Reserved	Word	1640	164000E		<input type="checkbox"/>	<input type="checkbox"/>	<input type="checkbox"/>	

IMG-ID: 184255371

5.8.2 Replacement of a PROFINET encoder in the network

Proceed as follows to replace a PROFINET encoder during operation:

- ✓ Make sure that the supply voltage of the encoder is disconnected.

- ✓ To allow device replacement without parameterizing, the options "Support device replacement without exchangeable medium" and "Permit overwriting of device names of all assigned IO devices" must be activated in the controller. See LLDP - Link Layer Discovery Protocol.

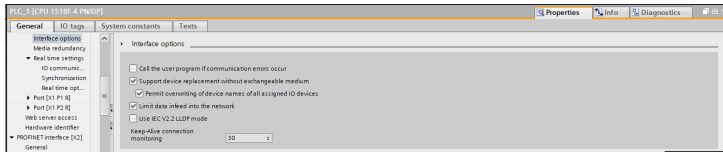

Fig. 2:

IMG-ID: 194693003

- a) Disconnect the Ethernet line(s) from the old encoder.
- b) Connect the Ethernet line(s) to the new encoder. Take care to connect the ports as they were with the old device.
- c) Connect the supply voltage to the encoder.
 - ⇒ An IP address and a name are assigned to the new encoder via LLDP. It is ready for operation after a few seconds.
- d) Depassivate the device and check the F-address Configuring the Encoder [▶ 27]
- e) Confirm the F-par CRC CRC value calculation [▶ 46]
- f) Deactivate bit 14 in G1_STW and activate bit 10 in STW2_ENC to disable the parking sensor.
 - ⇒ The new encoder is now ready for operation and issues position values.

6 Annex

6.1 Requirements for an Encoder Evaluation Device

Characteristic values of the encoder evaluation device for FS3 encoders

Designation	Value
Safety requirement	≥ SIL3 (compliant with IEC 61508)
Diagnostic coverage DC	≥ 99 %
Error presumptions	according to EN 61800-5-2

6.2 Definition Temperature Measurement

Under specific conditions, the maximum permissible ambient temperature must be limited. Therefore one also refers for encoders to a maximum operating temperature, which is composed of several components.

An encoder is a mechatronic system that heats up differently according to the variant. For critical applications close to the maximum values, determine the actual temperature of the encoder in operation.

Measuring point at the flange:

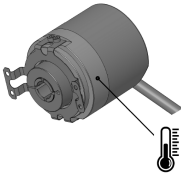

IMG-ID: 85632267

Both the ambient temperature and the mechanical and electrical self-heating are included when measuring the temperature on the flange.. Therefore, the temperature measured on the flange gives the operating temperature of the encoder.

NOTICE	Temperature range of connectable components
	When choosing the accessories, in particular the connectors, observe the maximum temperature of these components.

6.3 Scaling

The usability of the measured values output by the measuring system essentially depends on their scaling. Scaling the measured values presupposes that mathematical operations must be carried out, which, depending on the device type, are integrally or only partly supported. There are basically 3 different scaling types:

1. Binary scaling = Scaling function
2. Non-binary scaling = Universal Scaling function
3. Scaling by means of the gear factor = Gear Factor

6.4 Subnet mask in conjunction with the IP address

Each IP address can be subdivided into a network address and a host address. The subnet mask determines at which place this separation takes place. This basically determines the maximum possible number of host addresses and network addresses. The host addresses can be compared with the participants in an Ethernet network.

There are basically 3 address classes A, B and C.

Class A:

16,777,214 hosts per network

Subnet mask: 255.0.0.0

Maximum address range network address: 127,255,255,255

IP address 1st octet	IP address 2nd octet	IP address 3rd octet	IP address 3rd octet
1.	0.	0.	0.

Class B:

65,534 hosts per network

Subnet mask: 255.255.0.0

Maximum address range network address: 191,255,255,255

IP address 1st octet	IP address 2nd octet	IP address 3rd octet	IP address 4th octet
128.	1.	0.	0.

Class C:

254 hosts per network

Subnet mask: 255.255.255.0

Maximum address range network address: 223.255.255.255

IP address 1st octet	IP address 2nd octet	IP address 3rd octet	IP address 4th octet
192.	0.	1.	0.

The standard subnet mask is 255.255.255.0, thus allowing 254 network participants.

6.5 Conversion table Data types

Data type	Figure type	Length in bits	Length in bytes
BOOL	Binary	1	-
BYTE	Binary	8	1
WORD	Binary	16	2
DWORD	Binary	32	4
LWORD	Binary	64	8
SINT	Integer	8	1
INT	Integer	16	2
DINT	Integer	32	4
UINT	Integer	32	4
LINT	Integer	64	8
REAL	Floating point number	32	4
LREAL	Floating point number	64	8

6.6 Decimal / Hexadecimal conversion table

Dec	Hex	Dec	Hex	Dec	Hex	Dec	Hex	Dec	Hex
0	0x0	51	0x33	102	0x66	153	0x99	204	0xCC
1	0x1	52	0x34	103	0x67	154	0x9A	205	0xCD
2	0x2	53	0x35	104	0x68	155	0x9B	206	0xCE
3	0x3	54	0x36	105	0x69	156	0x9C	207	0xCF
4	0x4	55	0x37	106	0x6A	157	0x9D	208	0xD0
5	0x5	56	0x38	107	0x6B	158	0x9E	209	0xD1
6	0x6	57	0x39	108	0x6C	159	0x9F	210	0xD2
7	0x7	58	0x3A	109	0x6D	160	0xA0	211	0xD3
8	0x8	59	0x3B	110	0x6E	161	0xA1	212	0xD4
9	0x9	60	0x3C	111	0x6F	162	0xA2	213	0xD5
10	0xA	61	0x3D	112	0x70	163	0xA3	214	0xD6
11	0xB	62	0x3E	113	0x71	164	0xA4	215	0xD7
12	0xC	63	0x3F	114	0x72	165	0xA5	216	0xD8
13	0xD	64	0x40	115	0x73	166	0xA6	217	0xD9
14	0xE	65	0x41	116	0x74	167	0xA7	218	0xDA
15	0xF	66	0x42	117	0x75	168	0xA8	219	0xDB
16	0x10	67	0x43	118	0x76	169	0xA9	220	0xDC
17	0x11	68	0x44	119	0x77	170	0xAA	221	0xDD
18	0x12	69	0x45	120	0x78	171	0xAB	222	0xDE
19	0x13	70	0x46	121	0x79	172	0xAC	223	0xDF
20	0x14	71	0x47	122	0x7A	173	0xAD	224	0xE0
21	0x15	72	0x48	123	0x7B	174	0xAE	225	0xE1
22	0x16	73	0x49	124	0x7C	175	0xAF	226	0xE2
23	0x17	74	0x4A	125	0x7D	176	0xB0	227	0xE3
24	0x18	75	0x4B	126	0x7E	177	0xB1	228	0xE4
25	0x19	76	0x4C	127	0x7F	178	0xB2	229	0xE5
26	0x1A	77	0x4D	128	0x80	179	0xB3	230	0xE6
27	0x1B	78	0x4E	129	0x81	180	0xB4	231	0xE7
28	0x1C	79	0x4F	130	0x82	181	0xB5	232	0xE8
29	0x1D	80	0x50	131	0x83	182	0xB6	233	0xE9
30	0x1E	81	0x51	132	0x84	183	0xB7	234	0xEA

Dec	Hex	Dec	Hex	Dec	Hex	Dec	Hex	Dec	Hex
31	0x1F	82	0x52	133	0x85	184	0xB8	235	0xEB
32	0x20	83	0x53	134	0x86	185	0xB9	236	0xEC
33	0x21	84	0x54	135	0x87	186	0xBA	237	0xED
34	0x22	85	0x55	136	0x88	187	0xBB	238	0xEE
35	0x23	86	0x56	137	0x89	188	0xBC	239	0xEF
36	0x24	87	0x57	138	0x8A	189	0xBD	240	0xF0
37	0x25	88	0x58	139	0x8B	190	0xBE	241	0xF1
38	0x26	89	0x59	140	0x8C	191	0xBF	242	0xF2
39	0x27	90	0x5A	141	0x8D	192	0xC0	243	0xF3
40	0x28	91	0x5B	142	0x8E	193	0xC1	244	0xF4
41	0x29	92	0x5C	143	0x8F	194	0xC2	245	0xF5
42	0x2A	93	0x5D	144	0x90	195	0xC3	246	0xF6
43	0x2B	94	0x5E	145	0x91	196	0xC4	247	0xF7
44	0x2C	95	0x5F	146	0x92	197	0xC5	248	0xF8
45	0x2D	96	0x60	147	0x93	198	0xC6	249	0xF9
46	0x2E	97	0x61	148	0x94	199	0xC7	250	0xFA
47	0x2F	98	0x62	149	0x95	200	0xC8	251	0xFB
48	0x30	99	0x63	150	0x96	201	0xC9	252	0xFC
49	0x31	100	0x64	151	0x97	202	0xCA	253	0xFD
50	0x32	101	0x65	152	0x98	203	0xCB	254	0xFE
								255	0xFF

7 Contact

You want to get in touch with us:

Technical advice

For technical advice, analysis or support during installation, Kübler is directly on site with its globally active application team.

Support International (English-speaking)

+49 7720 3903 849

support@kuebler.com

Kübler Germany +49 7720 3903 849

Kübler Australia +61 3 7044 0090

Kübler China +86 10 8471 0818

Kübler France +33 3 89 53 45 45

Kübler India +91 8600 147 280

Kübler Italy +39 0 26 42 33 45

Kübler Austria +43 3322 43723 12

Kübler Poland +48 6 18 49 99 02

Kübler Turkey +90 216 999 9791

Kübler USA +1 855 583 2537

Repair service / RMA-Form

For returns, please pack the product adequately and enclose the completed "Returns Form".

www.kuebler.com/rma

Send your return, specifying the RMA-reference, to the following address.

Kübler Group Fritz Kübler GmbH

Schubertstraße 47
D-78054 Villingen-Schwenningen
Deutschland

Tel. +49 7720 3903 0

Fax +49 7720 21564

info@kuebler.com

www.kuebler.com

Glossary

BOOL

Data type. A BOOL (or Boolean) represents a truth value that may be either true or false.

CRC

Cyclic Redundancy Check

DINT

Data type. An operand of the data type DINT (double integer) has a length of 32 bits and is made of two components: a sign and a numerical value in two's complement.

DWORD

Data type. A DWORD consists of two WORDs, each consisting of 2 bytes, each of them consisting of 8 bits.

EMC

Electromagnetic compatibility

F-parameters

Failsafe related Parameters

INT

Data type. Integer. An integer is generally made of 16 bits.

iParameters

Individual / dynamic Parameters

IRT

Isochronous Real Time

LED

Light Emitting Diode. Semiconductor component that emits light.

LWORD

Data type. Long WORD consisting of two DWORDS.

MRP

Media Redundancy Protocol - For ring-shaped topologies

MRPD

Media Redundancy for Planned Duplication - Allows the seamless switching of the communication paths in the event of a failure of a communication branch such as e. g. a cable break.

MUR

Measuring Units per Revolution

PAP

Parameter Access Point

PNU

Parameter Number - Number of the respective PROFINET encoder parameter

RMA

Return Material Authorization, authorization to return material, e.g. in the case of complaints.

RT

Real Time - includes cycle times of up to 1 ms

SINT

Data type. Short integer. An operand of the data type SINT (short INT) has a length of 8 bits and is made of two components: a sign and a numerical value.

TCI

Tool Calling Interface - Interface through which an application program can be started from an existing application.

TMR

Total Measuring Range

UINT

Data type. An operand of the data type UINT (Unsigned INT) has a length of 16 bits and contains numerical values without sign.

USF

Universal Scaling Function, a non-binary scaling function (without overflow error)

WORD

Data type. A WORD includes 2 bytes, each of them including 8 bits.



Kübler Group
Fritz Kübler GmbH
Schubertstr. 47
D-78054 Villingen-Schwenningen
Germany
Phone +49 7720 3903-0
Fax +49 7720 21564
info@kuebler.com
www.kuebler.com